

# Flexform Indoor & Outdoor Collection 2021







# Flexform Indoor & Outdoor Collection 2021







Flexform 2021

4 / Indoor Collection  
204 / Outdoor Collection







# Indoor Collection 2021

La Collezione 2021 evoca lo spirito di un habitat contemporaneo nel quale l'atmosfera degli interni si riflette anche negli spazi esterni ed è caratterizzata da uno stile trasversale e da un'eleganza al di là del tempo e delle mode.

Una filosofia progettuale che è propria di Flexform e che affonda le sue radici nel know-how dell'azienda: l'orgoglio di pensare, progettare e realizzare oggetti fatti per durare nel tempo, per essere tramandati di padre in figlio, come un gioiello di famiglia.

Culto della tradizione e forte spinta all'innovazione sono i pilastri del patrimonio dell'azienda e continuano ad ispirarne l'attività.

I divani Harper e Bretton, le poltrone Lee e Tessa S.H., per citare solo alcuni tra i prodotti più emblematici della nuova collezione indoor manifestano appieno il saper fare insito nel DNA dell'azienda e di quell'intelligenza delle mani che conferisce un sapore unico ad ogni manufatto Flexform.

*The 2021 collection conjures the spirit of a contemporary habitat where the interior decor is also reflected in the outdoor spaces and embodies an all-encompassing style and timeless elegance untouched by fleeting fashions.*

*The roots of this signature Flexform design philosophy are deeply embedded in the company's know-how – spurring it to develop, design and craft objects made to last more than a lifetime, to be passed down to the next generation, like a family jewel.*

*A legacy of tradition and the drive to innovate are the mainstays of the company's heritage and continue to inspire its work.*

*The Harper and Bretton sofas, Lee and Tessa S.H. armchairs, to mention just some of the most emblematic products in the new indoor collection, fully embody the expertise inherent to the company's DNA and the skillful intelligence of the hands that lend a unique touch to each Flexform product.*



# Index

BRETTON



30

GREGORY XL



44

HARPER



8

LEE



66

BRETTON



30

ECHOES | ECHOES S.H.



112

GREGORY XL



44

ECHOES | ECHOES S.H.



112

GREGORY



44

LEE



66

MARLEY



78

MATE



162

ORTIGIA S.H.



102

TESSA S.H.



94

ECHOES | ECHOES S.H.



112

MARLEY



78

ORTIGIA S.H.



102



ANY DAY



184

BERRY



170

FLY



132

ZEFIRO



140

BERRY



170

ANY DAY



184

MATE



162

ASOLO



148



# Harper

Antonio Citterio

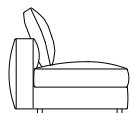

SOFAS  
SECTIONAL SOFAS  
OTTOMANS  
CHAISE LONGUES  
DAYBEDS

Harper è un sistema di sedute che rivela un'allure elegante grazie alle sue proporzioni equilibrate, alla confezione sartoriale dei rivestimenti e a dettagli di squisita manifattura. Elementi distintivi del divano Harper sono i braccioli contenitori rivestiti in cuoio.

Realizzati in una sottile lamina di metallo ricoperta in cuoio e disponibili in due larghezze, sono stati appositamente progettati per assolvere a diverse utilizzi: il vano può essere impiegato per riporre plaid, riviste, libri e un pratico ripiano può ospitare ordinatamente oggetti di uso comune quali i comandi da remoto. Nella vista laterale, così come in quella posteriore, il divano Harper presenta sofisticati particolari costruttivi che ne sottolineano la misurata eleganza.

La struttura generosamente imbottita è caratterizzata da dettagli in cuoio o in metallo disponibili in una pluralità di raffinate cromie e finiture. Il divano Harper è proposto in tre profondità - cm 99, cm 111 e cm 126 - e la varietà di elementi a disposizione così come le innumerevoli combinazioni che possono essere realizzate tra rivestimenti tessili, in pelle e i dettagli in cuoio lo rendono un sistema di sedute estremamente versatile, che può facilmente inserirsi negli ambienti più diversi.

*The Harper seating system has an innately elegant appeal, thanks to its balanced proportions, couture tailoring of the upholstery and exquisite handcrafted details. Saddle-hide-clad console armrests lend Harper distinctive good looks. Made of thin metal sheet clad in cowhide and available in two widths, the armrests are tailored to perform various functions.*

*The compartment can be used to store throws, magazines, books; the handy shelf provides at-hand organization of everyday items, like remotes.*

*Seen from the side and the back, the Harper sofa reveals refined construction details that highlight its understated elegance.*

*The generously padded structure is finished with cowhide or metal details, available in an array of sophisticated colors and finishes. The Harper sofa comes in three depths - 99 cm, 111 cm and 126 cm - and the numerous available elements, as well as the countless combinations that can be created between fabric and leather upholstery and cowhide details, make it an extraordinarily versatile seating system that is effortlessly at home in the most diverse settings.*







**Harper**  
Antonio Citterio













**Harper**  
Antonio Citterio





**Harper**  
Antonio Citterio









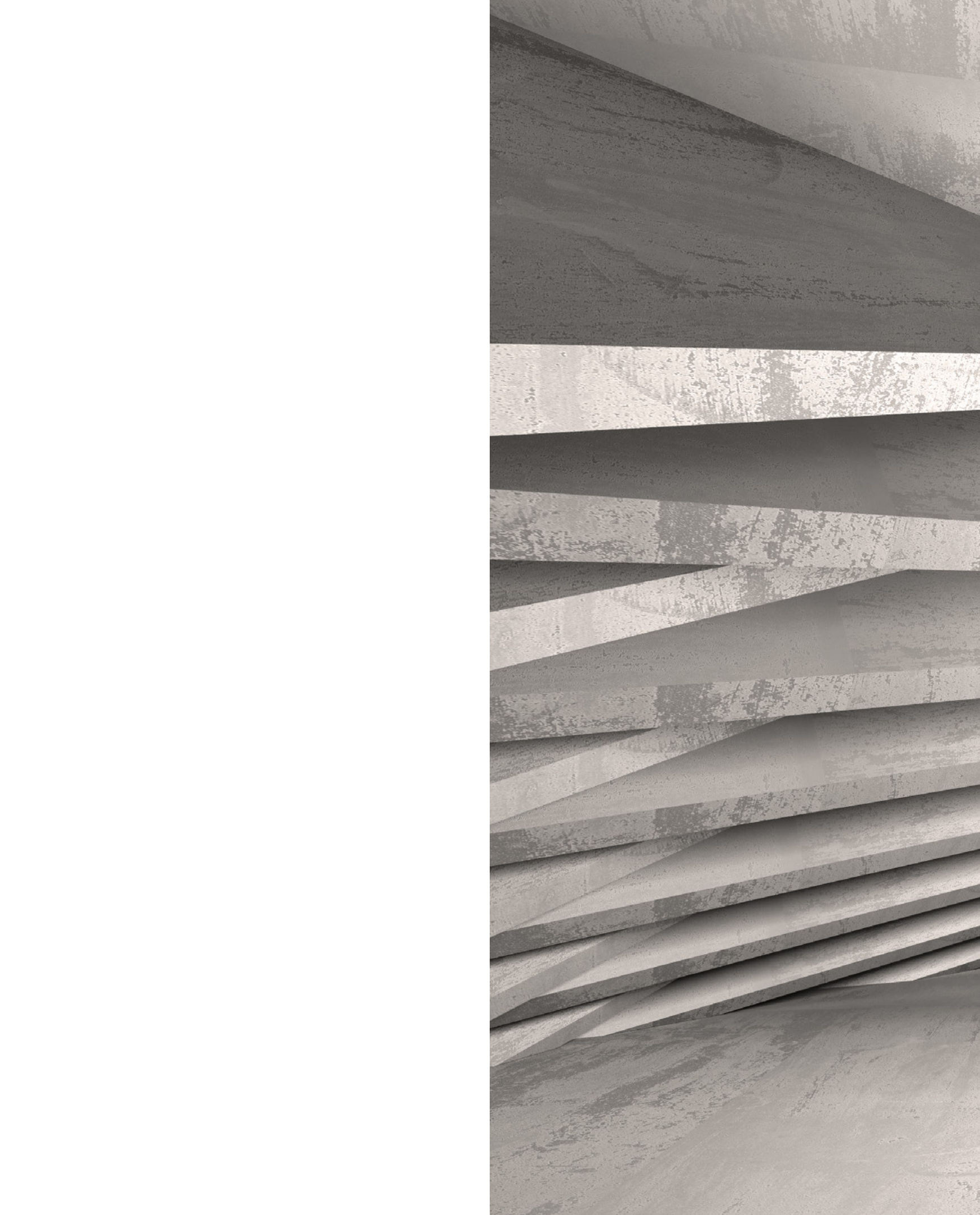



**Harper**  
Antonio Citterio





**Harper**  
Antonio Citterio







**Harper**  
Antonio Citterio









**Harper**  
Antonio Citterio





# Harper Data Sheet

Antonio Citterio

## Struttura

in legno con imbottitura in poliuretano espanso rivestito in tessuto protettivo accoppiato

## Schienale / Bracciolo

in metallo con imbottitura in poliuretano stampato e dacron, rivestiti in tessuto protettivo accoppiato

## Bracciolo portariviste

in metallo rivestito in cuoio nei colori: bianco (5007), grigio (5003), testa di moro (5004), testa di moro scuro (5013), nero (5005), oliva (5006), rosso bulgaro (5008), sabbia (5001), tabacco (5015), scamosciato moro (6004), scamosciato nero (6005), scamosciato oliva (6003), scamosciato sabbia (6001).

Piedi in metacrilato trasparente lucido

## Supporto schienale/bracciolo

in metallo rivestito in cuoio nei colori: bianco (5007), grigio (5003), testa di moro (5004), testa di moro scuro (5013), nero (5005), oliva (5006), rosso bulgaro (5008), sabbia (5001), tabacco (5015), scamosciato moro (6004), scamosciato nero (6005), scamosciato oliva (6003), scamosciato sabbia (6001); oppure nelle finiture cromato, satinato, brunito, cromo nero, canna di fucile. Di serie sul bracciolo imbottito; optional sullo schienale di ogni elemento, a richiesta con supplemento di prezzo

## Cuscini seduta

in fibra di poliestere con inserto in materiale indeformabile a densità unica. Seduta premium in piuma d'oca sterilizzata (certificata Assopiuma, Etichetta Oro) con inserto in materiale indeformabile ad alta resilienza

## Cuscini schienale

in piuma d'oca sterilizzata (certificata Assopiuma, Etichetta Oro)

## Cuscini optional

in piuma d'oca sterilizzata (certificata Assopiuma, Etichetta Oro), a richiesta con supplemento di prezzo

## Base

in metallo verniciato a forno con polveri epossidiche di colore nero. Appoggio a terra su puntali in materiale termoplastico

## Rivestimento

sfoderabile sia nella versione in tessuto che nella versione in pelle

## Profilo rivestimento

la confezione prevede un profilo in gros grain che può essere realizzato in tutti i colori della cartella campioni

## Structure

in wood with polyurethane foam padding covered with a protective laminated fabric

## Backrest / Armrest

in metal with molded polyurethane and Dacron padding, covered with a protective laminated fabric

## Magazine caddy armrest

in metal clad in cowhide in the following colors: white (5007), grey (5003), dark brown (5004), extra dark brown (5013), black (5005), olive (5006), Bulgarian red (5008), sand (5001), tobacco (5015), dark brown suede (6004), black suede (6005), olive suede (6003), sand suede (6001).

Feet made of glossy transparent methacrylate

## Backrest/armrest support

in metal clad in cowhide in the following colors: white (5007), grey (5003), dark brown (5004), extra dark brown (5013), black (5005), olive (5006), Bulgarian red (5008), sand (5001), tobacco (5015), dark brown suede (6004), black suede (6005), olive suede (6003), sand suede (6001); or with the following finishes: chrome, satin, burnished, black chrome, gunmetal. Standard on upholstered armrests; optional on all backrests, upon request with upcharge

## Seat cushions

in polyester fiber with insert in single-density crushproof material. Premium seat cushions in sterilized goose down (Assopiuma Certified, Gold Label) with insert in high resilience crushproof material

## Backrest cushions

in sterilized goose down (Assopiuma Certified, Gold Label)

## Optional cushions

in sterilized goose down (Assopiuma Certified, Gold Label); upon request, with upcharge

## Base

in black epoxy powder-coated metal. Rests on tips made of thermoplastic material

## Upholstery

is removable in both the fabric and leather versions

## Upholstery piping

fine tailoring includes grosgrain piping that can be crafted in all the colors on the sample board

28802 / 288A2

28803 / 288A3

28804 / 288A4

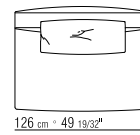
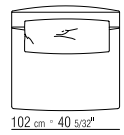
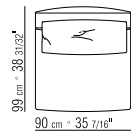
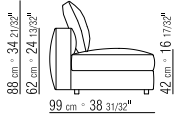

28805 / 288A5

28806 / 288A6

28807 / 288A7

28808 / 288A8

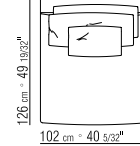
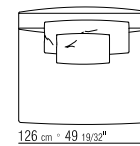
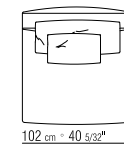
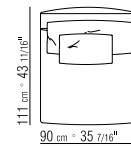
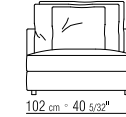
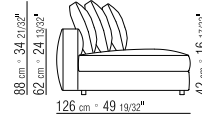
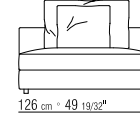
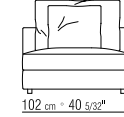
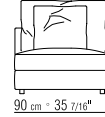
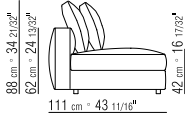

28823 / 288C3

28827 / 288C7

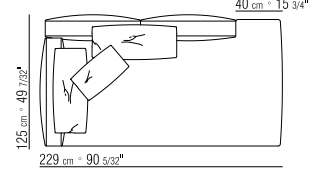
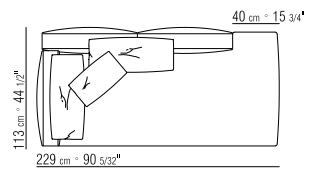
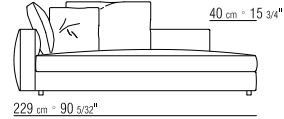
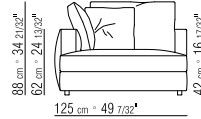
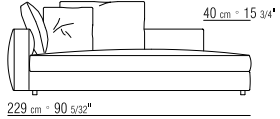
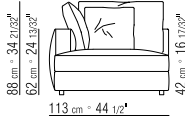



**Harper**  
Antonio Citterio

28831 / 288D1

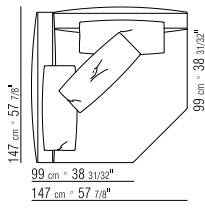
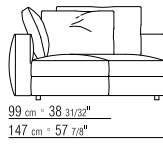
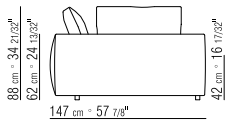

28837 / 288D7

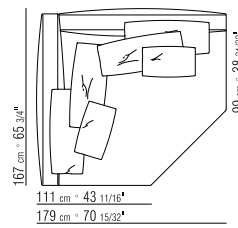
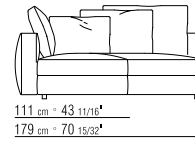
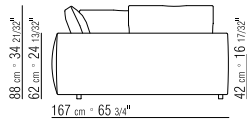

28838 / 288D8

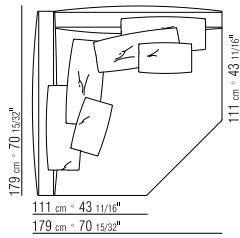
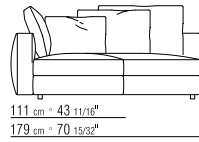
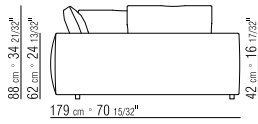

28841 / 288F1

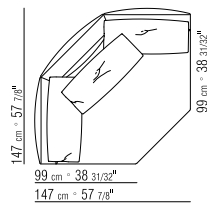
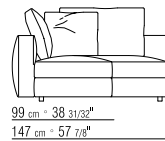
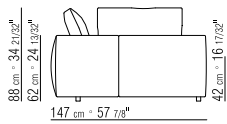

28847 / 288F7

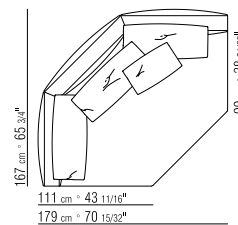
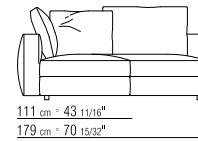
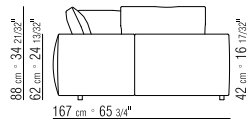

28848 / 288F8

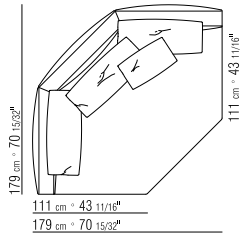
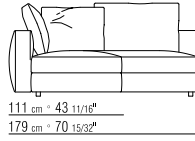
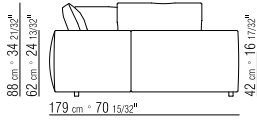

28850 / 288G0

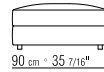
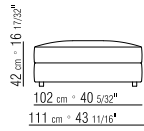
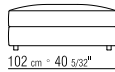
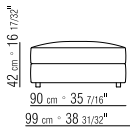

28852 / 288G2

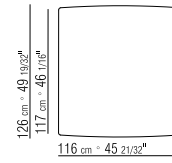
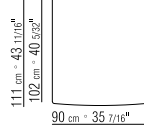
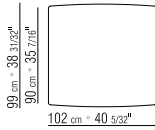
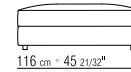
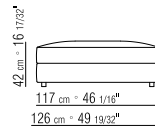

28870

28872

28874

28871

28873

28875

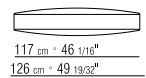
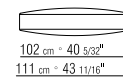
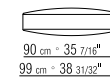
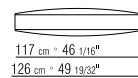
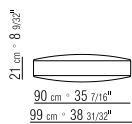
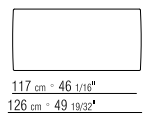
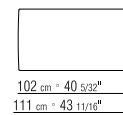
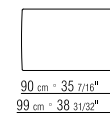
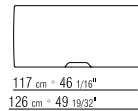
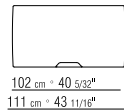
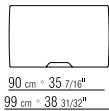



**Harper**  
Antonio Citterio

28876

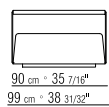
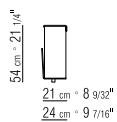

28877

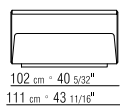

28878

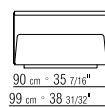
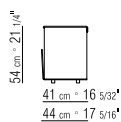

28879

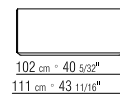
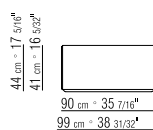
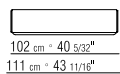
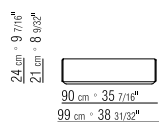
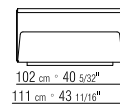

28895









# Bretton

Antonio Citterio

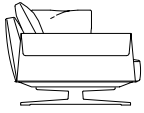

SOFAS  
SECTIONAL SOFAS  
OTTOMANS  
CHAISE LONGUES  
DAYBEDS

Il concept del divano Bretton mette al centro del progetto il cuoio, materiale nobile ed eterno prediletto da Flexform, che nel tempo ne ha sempre più affinato le tecniche di lavorazione. Gli ampi cuscini della seduta e dello schienale sono caratterizzati da imbottiture generose e raffinati dettagli di confezione quali il profilo in gros grain e creano un originale contrasto con la linea asciutta ed essenziale del bracciolo in metallo rivestito in cuoio in una varietà di colori come pure in cuoio scamosciato. Il divano appoggia su un'elegante base in metallo anch'essa rivestita in cuoio, mentre i piedi in alluminio pressofuso rivelano un disegno rigoroso e sono disponibili in una pluralità di sofisticate finiture. Bretton è un divano particolarmente versatile, che consente di realizzare innumerevoli combinazioni tra la struttura in cuoio e le parti imbottite, che possono essere rivestite sia in tessuto che in pelle.

*The concept for the Bretton sofa places cowhide at the heart of the design. This quintessential, timeless material is a favorite at Flexform and the company has consistently refined the craftsmanship techniques that make it a customer favorite. The roomy seat and backrest cushions are generously padded and feature elegant details - like the grosgrain piping - that contrast with the exquisite simplicity of the metal armrest clad in cowhide, available in an array of colors or in suede. The sofa rests on a refined metal base, also clad in cowhide, while the cast aluminum feet feature a sleek design and are available in a number of sophisticated finishes. An amazingly versatile sofa, Bretton offers countless combinations between the cowhide structure and the upholstered parts, which can be covered in fabric or in leather.*





**Bretton**  
Antonio Citterio









**Bretton**  
Antonio Citterio





**Bretton**  
Antonio Citterio







**Bretton**  
Antonio Citterio







# Bretton Data Sheet

Antonio Citterio

## Telaio seduta

in metallo rivestito in cuoio nei colori: bianco (5007), grigio (5003), testa di moro (5004), testa di moro scuro (5013), nero (5005), oliva (5006), rosso bulgaro (5008), sabbia (5001), tabacco (5015), scamosciato moro (6004), scamosciato nero (6005), scamosciato oliva (6003), scamosciato sabbia (6001).

Con materassino in poliuretano espanso

## Schienale

in metallo con imbottitura in poliuretano stampato rivestito in tessuto protettivo accoppiato

## Bracciolo

in metallo rivestito in cuoio nei colori: bianco (5007), grigio (5003), testa di moro (5004), testa di moro scuro (5013), nero (5005), oliva (5006), rosso bulgaro (5008), sabbia (5001), tabacco (5015), scamosciato moro (6004), scamosciato nero (6005), scamosciato oliva (6003), scamosciato sabbia (6001)

## Cuscini seduta

in fibra di poliestere con inserto in materiale indeformabile a densità unica.

Seduta premium in piuma d'oca sterilizzata (certificata Assopiuma, Etichetta Oro) con inserto in materiale indeformabile ad alta resilienza

## Cuscini schienale

in piuma d'oca sterilizzata (certificata Assopiuma, Etichetta Oro)

## Cuscini optional

in piuma d'oca sterilizzata (certificata Assopiuma, Etichetta Oro), a richiesta con supplemento di prezzo

## Piedi

in alluminio pressofuso nelle finiture colore grigio, bronzo 820, satinato, cromato, brunito, cromo nero, canna di fucile.

Appoggio a terra su puntali in materiale termoplastico

## Rivestimento

sfoderabile sia nella versione in tessuto che nella versione in pelle

## Profilo rivestimento

la confezione prevede un profilo in gros grain che può essere realizzato in tutti i colori della cartella campioni

## Seat frame

*in metal clad in cowhide in the following colors: white (5007), grey (5003), dark brown (5004), extra dark brown (5013), black (5005), olive (5006), Bulgarian red (5008), sand (5001), tobacco (5015), dark brown suede (6004), black suede (6005), olive suede (6003), sand suede (6001).*

*With polyurethane foam mattress*

## Backrest

*in metal with molded polyurethane padding, covered with a protective laminated fabric*

## Armrest

*in metal clad in cowhide in the following colors: white (5007), grey (5003), dark brown (5004), extra dark brown (5013), black (5005), olive (5006), Bulgarian red (5008), sand (5001), tobacco (5015), dark brown suede (6004), black suede (6005), olive suede (6003), sand suede (6001)*

## Seat cushions

*in polyester fiber with insert in single-density crushproof material.*

*Premium seat cushions in sterilized goose down (Assopiuma Certified, Gold Label) with insert in high resilience crushproof material*

## Backrest cushions

*in sterilized goose down (Assopiuma Certified, Gold Label)*

## Optional cushions

*in sterilized goose down (Assopiuma Certified, Gold Label); upon request, with upcharge*

## Feet

*in cast aluminum with grey, bronze 820, satin, chrome, burnished, black chrome, or gun metal finish. Rests on tips made of thermoplastic material*

## Upholstery

*is removable in both the fabric and leather versions*

## Upholstery piping

*fine tailoring includes grosgrain piping that can be crafted in all the colors on the sample board*

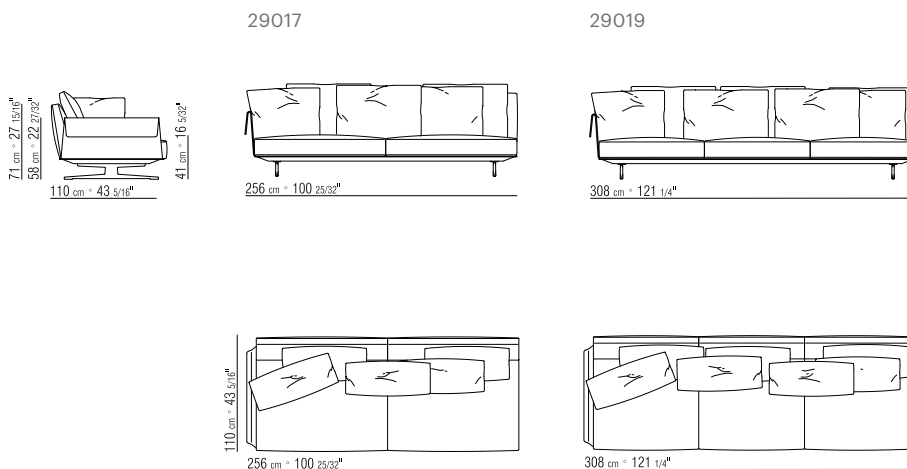
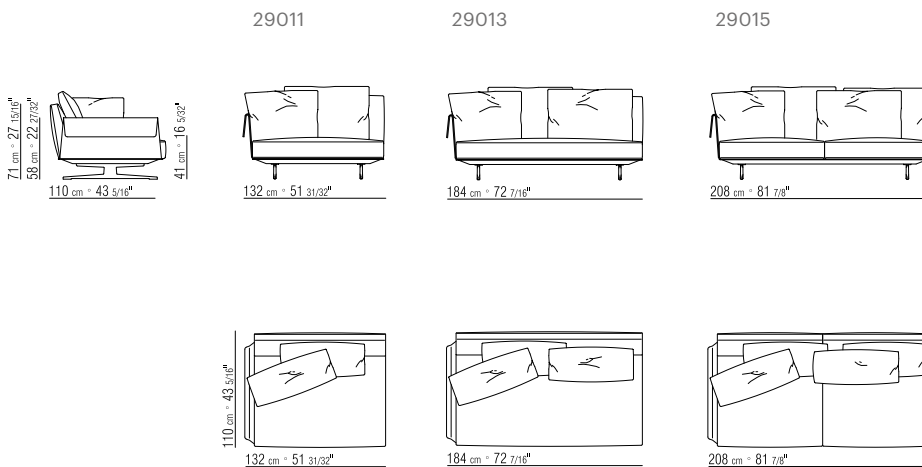
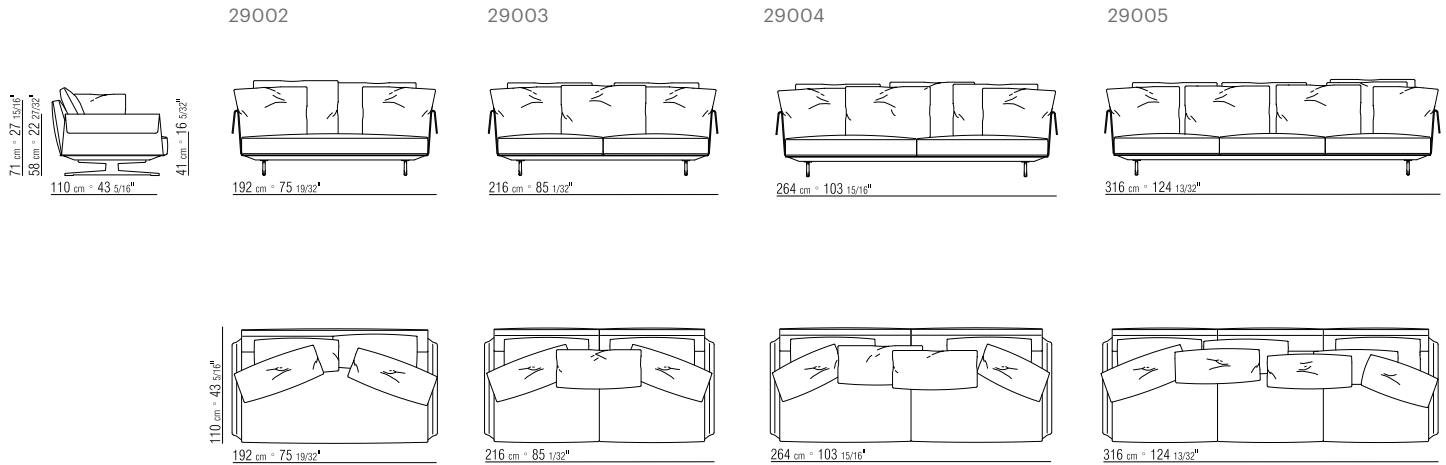



**Bretton**  
Antonio Citterio

29021

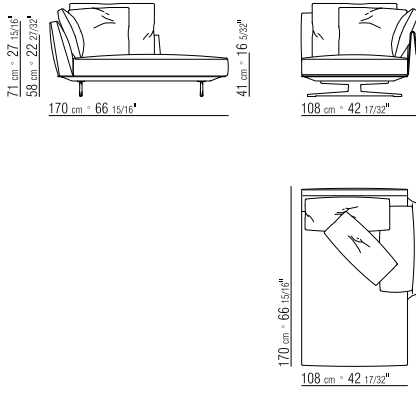

29027

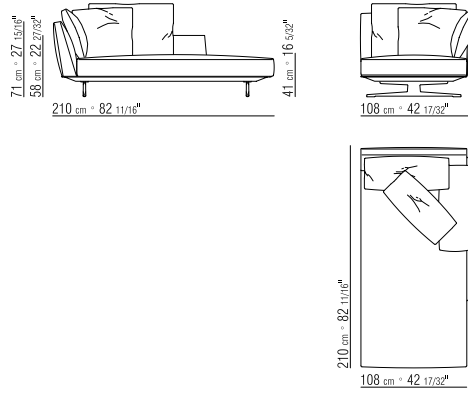

29031

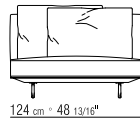
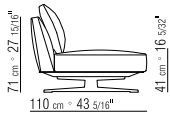

29032

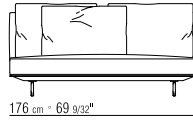

29033

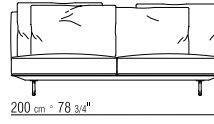

29034

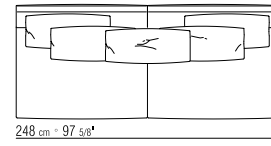
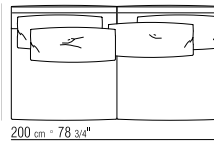
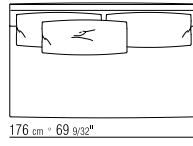
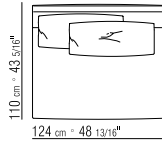
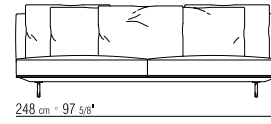

29098

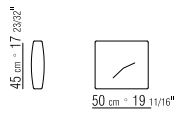

29099

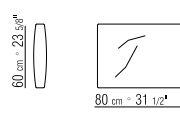





# Gregory XL | Gregory bench

Antonio Citterio

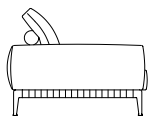

SOFAS  
SECTIONAL SOFAS  
OTTOMANS  
CHAISE LONGUES  
DAYBEDS

Il sistema di sedute Gregory amplia ulteriormente la propria componibilità attraverso una serie di nuovi elementi, caratterizzati da dimensioni importanti, che consentono di realizzare configurazioni dalle proporzioni generose pensate per offrire un elevato grado di confort e destinate ad interpretare un ruolo

da protagoniste nello spazio living. Il divano Gregory è caratterizzato da un'originale base in metallo il cui rigore si stempera nel connubio con il cuoio, materiale caldo e raffinato con il quale sono confezionate le parti a vista delle cinghie elastiche sulle quali appoggiano i cuscini di seduta.

Questa soluzione estetico-formale è riconducibile al saper fare che è proprio del patrimonio genetico dell'azienda, così come la confezione sartoriale dei profili in gros grain che rifiniscono i soffici cuscini. I cuscini di schienale con rullo imbottiti in piuma d'oca favoriscono una postura corretta durante la lettura e migliorano sensibilmente il livello di confort.

La struttura in metallo ed i piedi in alluminio pressofuso sono disponibili in una varietà di finiture che permette di realizzare sofisticati abbinamenti con il cuoio delle cinghie che è proposto nei colori tabacco, testa di moro, grigio e nero.

La raffinata estetica che caratterizza la base del divano Gregory ha generato anche una serie di sedute - panche realizzate in tre misure - pensate in abbinamento alle diverse tipologie di tavoli della collezione Flexform e disponibili nelle medesime finiture del divano.

*The Gregory seating system further expands its modular options through a series of new pieces, distinguished by their impressive size, that can be assembled into generously proportioned arrangements designed to offer a superior level of comfort and are sure to play a starring role in the living room.*

*The Gregory sofa's personality is evident in the austerity of the unique metal base that is softened by the warmth of the elegant cowhide finish on the exposed parts of the elastic webbing that supports the seat cushions.*

*Just like the couture tailoring of the grosgrain piping that outlines the soft cushions, this formal-aesthetic solution traces back to the expertise that lies at the core of the company's genetic legacy. The goose-down-filled backrest cushions and bolster noticeably improve comfort and promote proper ergonomics while enjoying a good read.*

*The metal structure and cast aluminum feet come in a variety of finishes that invite sophisticated color pairings with the cowhide webbing, available in tobacco, dark brown, grey and black. The tasteful aesthetic evident in the base of the Gregory sofa led to a series of benches, available in three sizes, designed for pairing with the various types of tables in the Flexform collection and available in the same finishes as the sofa.*



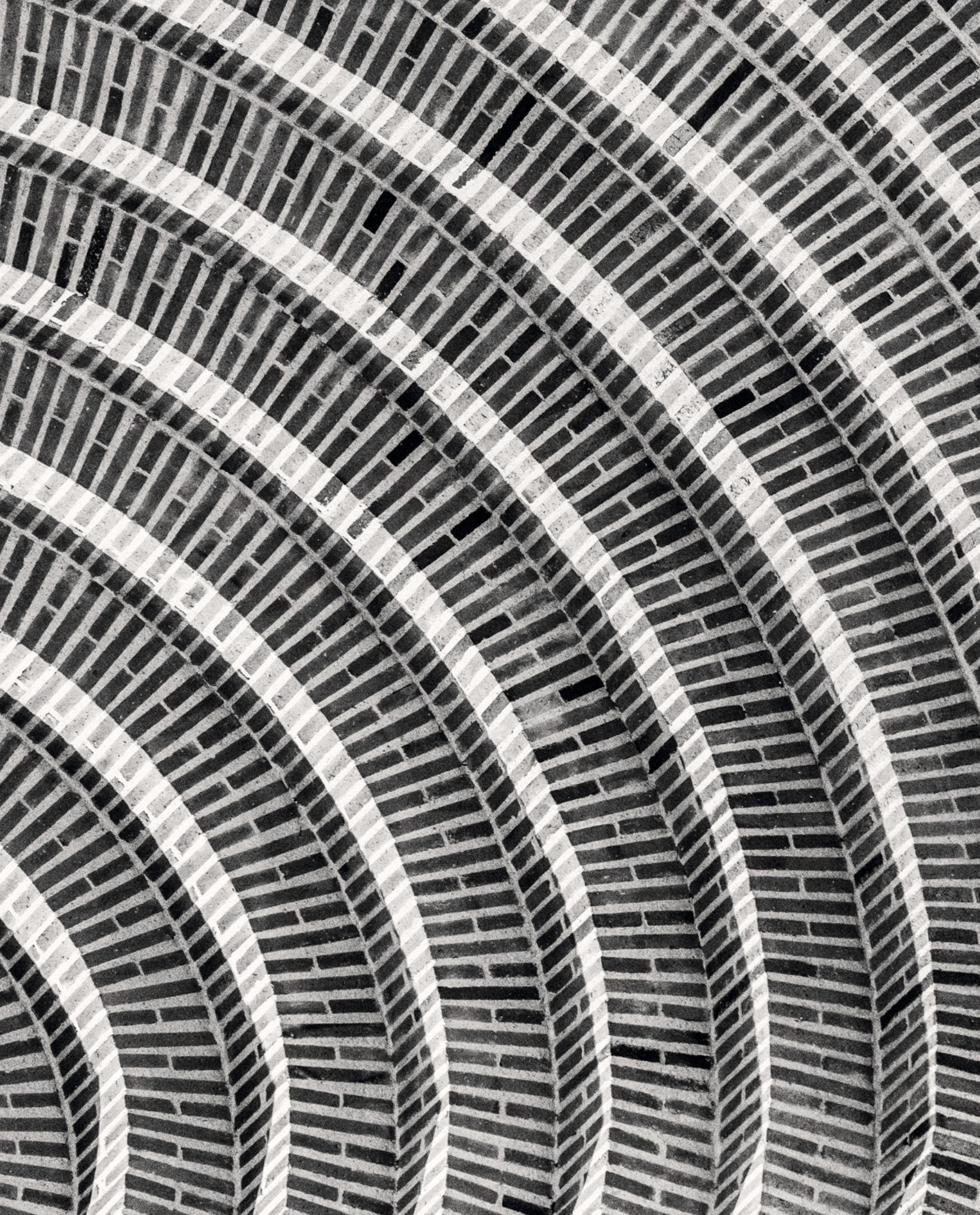



**Gregory XL**  
Antonio Citterio











**Gregory XL**  
Antonio Citterio





**Gregory XL**  
Antonio Citterio







**Gregory XL**  
Antonio Citterio







**Gregory XL**  
Antonio Citterio









**Gregory bench**  
Antonio Citterio





**Gregory bench**  
Antonio Citterio



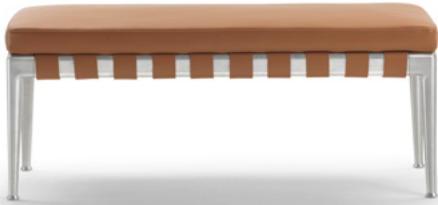



# Gregory XL

## Data Sheet

Antonio Citterio

### Struttura

in metallo nella finitura brunito e canna di fucile rivestita con cinghie elastiche rifinite in cuoio nei colori nero (5005), testa di moro (5004), tabacco (5015), grigio (5003)

### Struttura versione Finish Plus

in metallo nelle finiture satinato, cromato, cromo nero rivestita con cinghie elastiche rifinite in cuoio nei colori nero (5005), testa di moro (5004), tabacco (5015), grigio (5003)

### Cuscini seduta

in fibra di poliestere con inserto in materiale indeformabile a densità unica

### Schienale / Bracciolo

in metallo con imbottitura in poliuretano stampato e dacron, rivestiti in tessuto protettivo accoppiato

### Cuscini schienale

in piuma d'oca sterilizzata (certificata Assopiuma, Etichetta Oro), con rullo reggiscuscino in fibra di poliuretano

### Cuscini optional

in piuma d'oca sterilizzata (certificata Assopiuma, Etichetta Oro), a richiesta con supplemento di prezzo

### Piedi

in alluminio pressofuso nella finitura brunito e canna di fucile. Appoggio a terra su puntali in materiale termoplastico

### Piedi versione Finish Plus

in alluminio pressofuso nelle finiture satinato, cromato, cromo nero. Appoggio a terra su puntali in materiale termoplastico

### Rivestimento

sfoderabile sia nella versione in tessuto che nella versione in pelle

### Profilo rivestimento

la confezione prevede un profilo in gros grain che può essere realizzato in tutti i colori della cartella campioni

### Structure

in burnished or gun metal finish with elastic webbing finished in black (5005), dark brown (5004), tobacco (5015) or grey (5003) color cowhide

### Finish Plus version structure

in metal with satin, chrome or black chrome finish with elastic webbing finished in black (5005), dark brown (5004), tobacco (5015) or grey (5003) color cowhide

### Seat cushions

in polyester fiber with insert in single-density crushproof material

### Backrest / Armrest

in metal with molded polyurethane and Dacron padding, covered with a protective laminated fabric

### Backrest cushions

in sterilized goose down (Assopiuma certified, Gold label) with polyurethane fiber support bolster

### Optional cushions

in sterilized goose down (Assopiuma certified, Gold label); upon request, with upcharge

### Feet

in cast aluminum with burnished or gun metal finish. Feet rest on tips made of thermoplastic material

### Finish Plus version feet

in cast aluminum with satin, chrome, black chrome finish. Feet rest on tips made of thermoplastic material

### Upholstery

is removable in both the fabric and leather versions

### Upholstery piping

fine tailoring includes grosgrain piping that can be crafted in all the colors on the sample board

28703 / 287A3

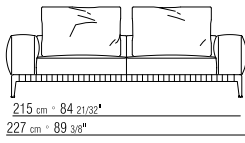
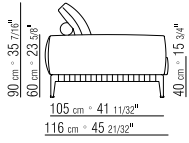

28705 / 287A5

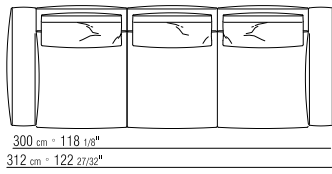
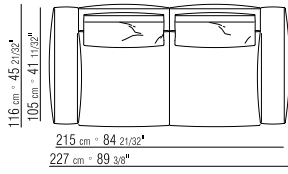
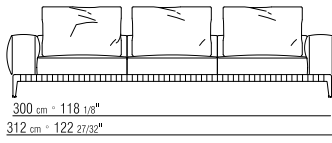

28713 / 287B3

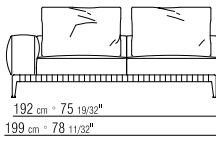
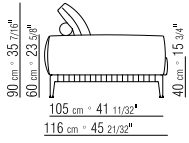

28717 / 287B7

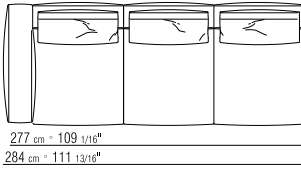
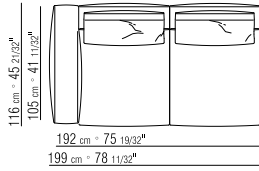
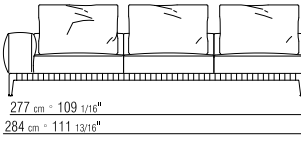

28715 / 287B5

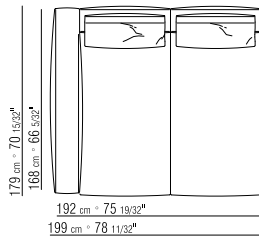
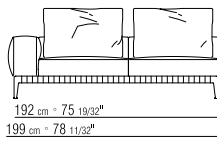
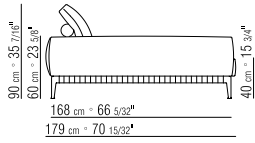



**Gregory XL**  
Antonio Citterio

28723 / 287C3

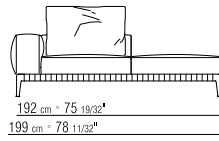
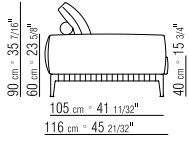

28727 / 287C7

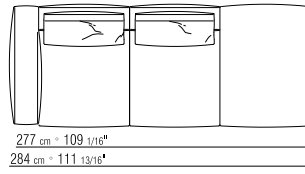
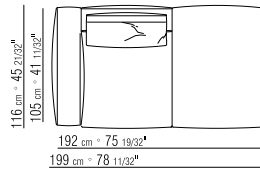
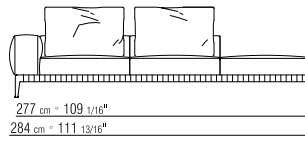

28743 / 287F3

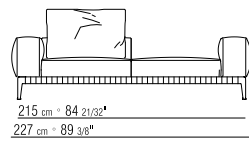
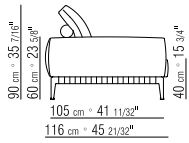

28747 / 287F7

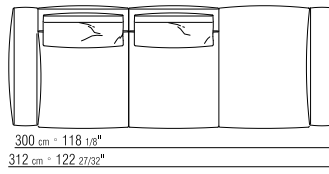
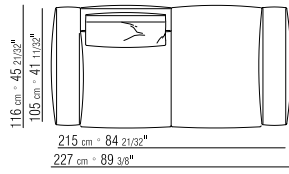
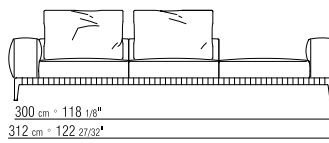

28708 / 287A8

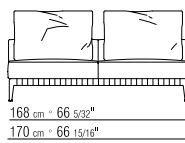
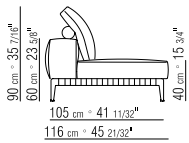

28730 / 287D0

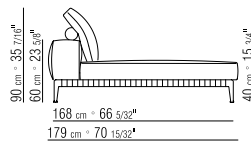

28731 / 287D1

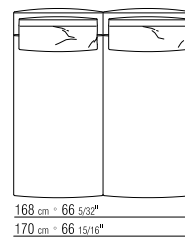
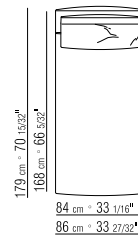
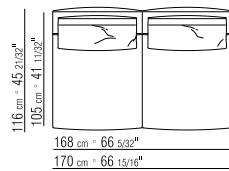
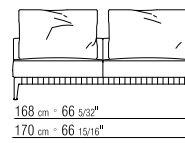

28751 / 287G1

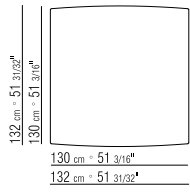
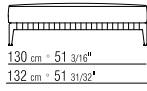
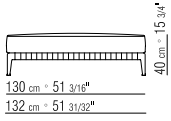

28752 / 287G2

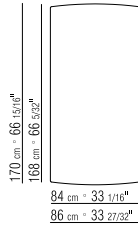
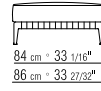
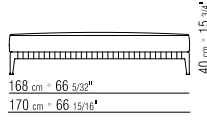

28753 / 287G3

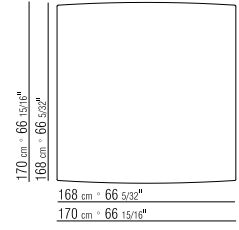
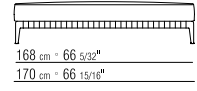
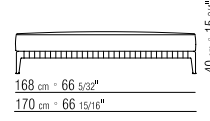

# Gregory bench

## Data Sheet

Antonio Citterio

### Struttura

in alluminio nella finitura brunito e canna di fucile. Fasce in cuoio nei colori nero (5005), testa di moro (5004), tabacco (5015), grigio (5003)

### Struttura versione Finish Plus

in alluminio nelle finiture satinato, cromato, cromo nero. Fasce in cuoio nei colori nero (5005), testa di moro (5004), tabacco (5015), grigio (5003)

### Cuscino seduta

in poliuretano espanso con inserto in legno multistrato rivestito in tessuto protettivo accoppiato

### Piedi

in alluminio pressofuso nella finitura brunito, canna di fucile. Appoggio a terra su puntali in materiale termoplastico

### Piedi versione Finish Plus

in alluminio pressofuso nelle finiture satinato, cromato, cromo nero. Appoggio a terra su puntali in materiale termoplastico

### Rivestimento

sfoderabile sia nella versione in tessuto che nella versione in pelle

### Structure

*in aluminum with burnished or gun metal finish. Cowhide webbing in black (5005), dark brown (5004), tobacco (5015), grey (5003)*

### Finish Plus version structure

*in aluminum with satin, chrome or black chrome finish. Cowhide webbing in black (5005), dark brown (5004), tobacco (5015), grey (5003)*

### Seat cushion

*in polyurethane foam with plywood insert, covered with a protective laminated fabric*

### Feet

*in cast aluminum with burnished or gun metal finish. Rests on tips made of thermoplastic material*

### Finish Plus version feet

*in cast aluminum with satin, chrome or black chrome finish. Rests on tips made of thermoplastic material*

### Upholstery

*is removable in both the fabric and leather versions*



---

27155 / 271G5

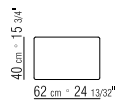
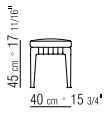

27156 / 271G6

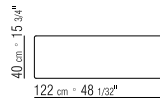
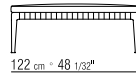
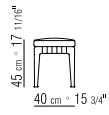

27157 / 271G7

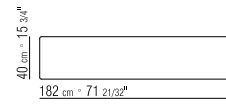
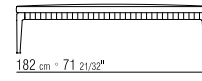

# Lee

Antonio Citterio



SOFAS  
SECTIONAL SOFAS  
ARMCHAIRS  
OTTOMANS

Design come memoria: una poetica semplicità e suggestioni legate a ricordi d'infanzia hanno ispirato il concept della poltrona e del divanetto Lee.

La struttura in legno massello - frassino e noce canaletto - è interamente realizzata a mano così come l'intreccio dello schienale e della seduta, per il quale è stata scelta la paglia di fiume, un materiale considerato desueto ma completamente naturale e dotato di un'eccellente resistenza all'usura, qui recuperato in omaggio alla tradizione, con l'orgoglio di dar vita a qualcosa destinato a durare nel tempo, ad essere tramandato a chi verrà dopo di noi.

La poltrona ed il divanetto Lee prevedono anche la possibilità di aggiungere dei soffici cuscini optional dal rivestimento sfoderabile.

*Design as memory: conceptual simplicity and influences tied to childhood memories inspired the design of the Lee armchair and settee. The solid wood structure - in ash and Canaletto walnut - is entirely hand-crafted, as are the woven backrest and seat made of paper rush cord. This old-fashioned but completely natural material with excellent resistance to wear is revived here as a tribute to tradition, with the satisfaction of creating something that will last a lifetime and be passed down to the next generations.*

*Both the Lee armchair and settee offer the option of adding soft cushions with removable upholstery.*







**Lee**  
Antonio Citterio



**Lee**  
Antonio Citterio







**Lee**  
Antonio Citterio







**Lee**  
Antonio Citterio





# Lee

## Data Sheet

Antonio Citterio

### Struttura

in legno massello di noce canaletto nelle finiture naturale, tinto extra, tinto caffè o massello di frassino nelle finiture naturale, tinto noce, tinto ciliegio, tinto teak, tinto caffè, tinto wengé, tinto ebano, tinto marrone. Intreccio in paglia di fiume ritorta

### Cuscino seduta/schienale

in fibra di poliestere. Su richiesta e con supplemento di prezzo

### Piedi

in zama pressofusa nelle finiture satinato, cromato, brunito, cromo nero, canna di fucile. Appoggio a terra su puntali in materiale termoplastico

### Rivestimento cuscini seduta/schienale

sfoderabile sia nella versione in tessuto che nella versione in pelle

### Structure

*in solid Canaletto walnut with natural finish; or, stained Canaletto walnut extra or coffee; or, in solid ash with natural finish or stained walnut, cherry, teak, coffee, wenge, ebony or brown.  
Woven twisted paper rush cord*

### Seat/backrest cushion

*in polyester fiber; upon request, with upcharge*

### Feet

*in die-cast zama with satin, chrome, black chrome, burnished or gun metal finish.  
Feet rest on tips made of thermoplastic material*

### Seat and backrest cushion upholstery

*is removable in both the fabric and leather versions*



28421

28403

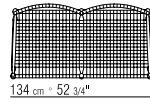
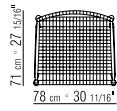
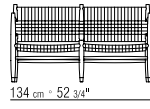
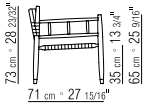

28499

28498

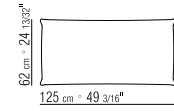
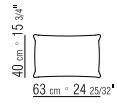
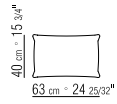
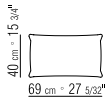

# Marley

Antonio Citterio



ARMCHAIRS  
OTTOMANS  
DINING CHAIRS  
DINING ARMCHAIRS  
BAR STOOLS

La famiglia di sedute Marley è connotata da forme morbide e da un design rigoroso che le colloca in perfetto equilibrio tra allure classica e spirito contemporaneo.

L'avvolgente scocca della poltrona è in metallo e poliuretano espanso mentre i cuscini di seduta e schienale sono imbottiti in piuma d'oca, per garantire un elevato livello di confort.

La base di appoggio della poltrona Marley è proposta in una pluralità di varianti che sono riconducibili a diverse interpretazioni stilistiche e anche a differenti fruizioni.

Nella sua versione più classica, la poltrona Marley poggia su una base in legno massello, nelle essenze noce canaletto o frassino proposte in varie tinte.

Un'interpretazione più rigorosa della poltrona è quella con base girevole a cinque razze realizzata in alluminio pressofuso, che rivela cambi di spessore, angoli smussati, curve calibrate.

Particolarmente funzionale la versione nella quale la struttura in metallo che sostiene la scocca è caratterizzata nella parte posteriore da un dettaglio rivestito in pelle che assolve alla funzione di maniglia e consente di spostare facilmente la poltrona all'interno dell'ambiente. Questa ultima variante prevede anche la possibilità di montare due agili ruote pivotanti sulle gambe anteriori per facilitarne ulteriormente la movimentazione.

La famiglia Marley comprende anche sedie, poltroncine da pranzo e sgabelli caratterizzate dai medesimi dettagli estetici dell'omonima poltrona.

Tutte le poltrone e le sedie della famiglia Marley sono completamente sfoderabili e vestono con eguale disinvoltura tutte le pelli ed i tessuti dell'esclusiva collezione Flexform.

*The Marley family of seating is distinguished by its soft shapes and sleek design, the ideal blend of classic appeal and contemporary spirit.*

*The enveloping shell of the armchair is in metal and polyurethane foam while the seat and backrest cushions are filled with goose down to ensure superior comfort.*

*The base of the Marley armchair is available in an array of versions whose design roots trace back to different stylistic interpretations and even different uses.*

*In its most classic version, the Marley armchair rests on a solid wood base, in Canaletto walnut or ash, with a variety color options.*

*A more formal interpretation of the armchair has a swivel base with five spokes made of cast aluminum, of varying thicknesses, with rounded corners and well-balanced curves.*

*Functionality is key in the version with a metal structure that supports the shell. A leather-covered handle detail on the back allows the armchair to be easily moved.*

*This latter version can also be outfitted with two swivel casters on the front legs to further facilitate movement.*

*The Marley family also includes chairs, dining chairs and stools imbued with the same aesthetic details as the namesake armchair.*

*The upholstery on all of the armchairs and chairs in the Marley family is completely removable and equally at ease in any of the leathers and fabrics in the exclusive Flexform collection.*







**Marley**  
Antonio Citterio



**Marley**  
Antonio Citterio







**Marley**  
Antonio Citterio









**Marley**  
Antonio Citterio



**Marley**  
Antonio Citterio







**Marley**  
Antonio Citterio







# Marley Data Sheet

Antonio Citterio

## Poltrona

### Struttura

in poliuretano stampato rivestito in tessuto protettivo accoppiato

### Cuscino seduta

in piuma d'oca sterilizzata (certificata Assopiuma, Etichetta Oro) con inserto in materiale indeformabile a densità differenziata

### Cuscino schienale

in piuma d'oca sterilizzata (certificata Assopiuma, Etichetta Oro)

### Base girevole

in alluminio pressofuso nelle finiture satinato, cromato, brunito, cromo nero, canna di fucile. Appoggio a terra su puntali in materiale termoplastico

### Base fissa in metallo

nelle finiture satinato, cromato, brunito, cromo nero, canna di fucile. appoggio a terra su puntali in materiale termoplastico. Maniglia ricoperta in pelle, la scelta della pelle è da effettuarsi previa verifica della possibilità di utilizzo. Base fissa disponibile anche nella versione con ruote anteriori e maniglia rivestita in pelle

### Base fissa in legno

massello di noce canaletto nelle finiture naturale, tinto extra, tinto caffè o massello di frassino nelle finiture naturale, tinto noce, tinto ciliegio, tinto teak, tinto caffè, tinto wengé, tinto ebano, tinto marrone. Appoggio a terra su puntali in materiale termoplastico

### Rivestimento

sfoderabile sia nella versione in tessuto che nella versione in pelle

## Sedia / Poltroncina / Sgabello

### Base fissa

in metallo nelle finiture satinato, cromato, brunito, cromo nero e canna di fucile. Appoggio a terra su puntali in materiale termoplastico. Maniglia ricoperta in pelle, la scelta della pelle è da effettuarsi previa verifica della possibilità di utilizzo

### Base fissa in legno

massello di noce canaletto nelle finiture naturale, tinto extra, tinto caffè o massello di frassino nelle finiture naturale, tinto noce, tinto ciliegio, tinto teak, tinto caffè, tinto wengé, tinto ebano, tinto marrone. Per lo sgabello è previsto il poggiatesta in acciaio. Appoggio a terra su puntali in materiale termoplastico

### Rivestimento

sfoderabile sia nella versione in tessuto che nella versione in pelle

## Armchair

### Structure

in molded polyurethane covered with a protective laminated fabric

### Seat cushion

in sterilized goose down (Assopiuma Certified, Gold Label) with insert in crushproof, variable density material

### Backrest cushion

in sterilized goose down (Assopiuma Certified, Gold Label)

### Swivel base

in cast aluminum with satin, chrome, burnished, black chrome or gun metal finish. Rests on tips made of thermoplastic material

### Stationary base in metal

with satin, chrome, burnished, black chrome or gun metal finish. Rests on tips made of thermoplastic material. Leather-covered handle (leather choice requires verification that it is suitable for this purpose). Stationary base also available with front wheels and handle covered in leather

### Stationary base

in solid Canaletto walnut with natural finish, or stained Canaletto walnut extra or coffee; or, in solid ash with natural finish or stained walnut, cherry, teak, coffee, wenge, ebony or brown. Rests on tips made of thermoplastic material

### Upholstery

is removable in both the fabric and leather versions

## Product Chair / Small Armchair / Bar Stool

### Metal stationary base

in metal with satin, chrome, burnished, black chrome or gun metal finish. Rests on tips made of thermoplastic material. Leather-covered handle (leather choice requires verification that it is suitable for this purpose)

### Wooden stationary base

in solid Canaletto walnut with natural finish, or stained Canaletto walnut extra or coffee; or, in solid ash with natural finish or stained walnut, cherry, teak, coffee, wenge, ebony or brown. The bar stool has a steel footrest. Rests on tips made of thermoplastic material

### Upholstery

is removable in both the fabric and leather versions

28601/28602

81 cm · 31 7/8"  
56 cm · 22 1/4"  
45 cm · 17 23/32"



51 cm · 20 3/32"



51 cm · 20 3/32"

28603

81 cm · 31 7/8"  
58 cm · 22 27/32"  
45 cm · 17 23/32"

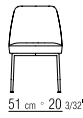

51 cm · 20 3/32"



51 cm · 20 3/32"

28611/28612

81 cm · 31 7/8"  
61 cm · 24 1/2"  
45 cm · 17 23/32"



57 cm · 22 7/16"

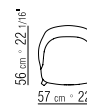

57 cm · 22 7/16"

28613

81 cm · 31 7/8"  
61 cm · 24 1/2"  
45 cm · 17 23/32"



57 cm · 22 7/16"



57 cm · 22 7/16"

28621/28622

82 cm · 32 3/8"  
58 cm · 22 27/32"  
41 cm · 16 5/32"  
86 cm · 33 27/32"



70 cm · 27 9/16"

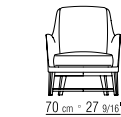

70 cm · 27 9/16"



70 cm · 27 9/16"

28623

82 cm · 32 3/8"  
58 cm · 22 27/32"  
41 cm · 16 5/32"  
86 cm · 33 27/32"



70 cm · 27 9/16"



70 cm · 27 9/16"



70 cm · 27 9/16"

28624

82 cm · 32 3/8"  
58 cm · 22 27/32"  
41 cm · 16 5/32"  
86 cm · 33 27/32"



70 cm · 27 9/16"



70 cm · 27 9/16"

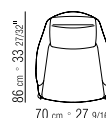

70 cm · 27 9/16"

28625

82 cm · 32 3/8"  
58 cm · 22 27/32"  
41 cm · 16 5/32"  
86 cm · 33 27/32"



70 cm · 27 9/16"



70 cm · 27 9/16"



70 cm · 27 9/16"

28651/28652

87 cm · 34 1/4"  
51 cm · 20 3/32"  
65 cm · 25 13/32"



47 cm · 18 1/2"



47 cm · 18 1/2"

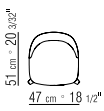

47 cm · 18 1/2"

28653

87 cm · 34 1/4"  
54 cm · 21 1/4"  
65 cm · 25 13/32"



47 cm · 18 1/2"



47 cm · 18 1/2"

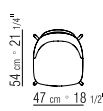

47 cm · 18 1/2"

# Tessa S.H.

Antonio Citterio



ARMCHAIRS  
OTTOMANS

La poltrona Tessa S.H. rappresenta il punto di incontro tra una struttura in legno lavorata secondo la grande tradizione dell'ebanisteria italiana e l'impiego di un materiale nobile ed eterno come il cuoio.

La struttura della poltrona Tessa S.H. è interamente realizzata in pregiato legno massello di frassino, noce canaletto e mogano.

Gli incastri e le rifiniture sono eseguiti manualmente, con tecniche di lavorazione che richiedono grande perizia artigianale, volte a valorizzare le qualità intrinseche di un materiale caldo e naturale come il legno.

La versione in massello di mogano è disponibile unicamente con finitura lucida.

La seduta e lo schienale della poltrona Tessa S.H. sono invece realizzati in cuoio e quest'ultimo è caratterizzato nella parte posteriore da raffinate cuciture che impreziosiscono la confezione della poltrona.

La poltrona Tessa S.H. può essere corredata da un poggiatesta realizzato nelle medesime finiture.

*The Tessa S.H. armchair is an iconic combination of a wood structure crafted in the fine Italian cabinetmaking tradition and a quintessential, timeless material like cowhide.*

*The structure of the Tessa S.H. armchair is made entirely of prized solid ash wood, Canaletto walnut or mahogany. The joints and finishes are hand-crafted using techniques that require expert artisan skill and highlight the inherent qualities of a warm, natural material like wood.*

*The solid mahogany version is only available with glossy finish.*

*The seat and backrest of the Tessa S.H. armchair are made of cowhide and the posterior of the backrest features sophisticated top stitching that underscores the chair's refined craftsmanship.*

*The Tessa S.H. armchair can be paired with a footstool in the same finishes.*





**Tessa S.H.**  
Antonio Citterio











**Tessa S.H.**  
Antonio Citterio



# Tessa S.H. Data Sheet

Antonio Citterio

## Struttura

in legno massello di noce canaletto nelle finiture naturale, tinto extra, tinto caffè o massello di frassino nelle finiture naturale, tinto noce, tinto ciliegio, tinto teak, tinto caffè, tinto wengé, tinto ebano, tinto marrone; in massello di mogano verniciato lucido

## Seduta/schienale

in cuoio nei colori: bianco (5007), grigio (5003), testa di moro (5004), testa di moro scuro (5013), nero (5005), oliva (5006), rosso bulgaro (5008), sabbia (5001), tabacco (5015)

## Piedi

in zama pressofusa nelle finiture satinato, cromato, brunito, cromo nero, canna di fucile. Appoggio a terra su puntali in materiale termoplastico

## Structure

*in solid Canaletto walnut with natural finish; or, stained Canaletto walnut extra or coffee; or, in solid ash with natural finish or stained walnut, cherry, teak, coffee, wenge, ebony or brown; or, in solid mahogany with glossy varnished finish*

## Seat/Backrest

*in cowhide in the following colors: white (5007), grey (5003), dark brown (5004), extra dark brown (5013), black (5005), olive (5006), Bulgarian red (5008), sand (5001), tobacco (5015)*

## Feet

*in die-cast zama with satin, chrome, burnished, black chrome or gun metal finish. Rests on tips made of thermoplastic material*



27222

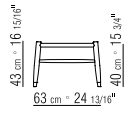

27251

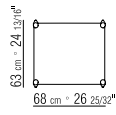

27253

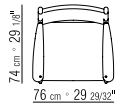
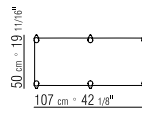
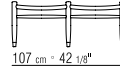
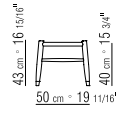

# Ortigia S.H.

Design Center



ARMCHAIRS  
OTTOMANS  
DINING CHAIRS  
DINING ARMCHAIRS  
BAR STOOLS

Ortigia S.H. è il nome di una famiglia di sedute connotata da un fascino borghese rivisitato in chiave contemporanea e rifinita da particolari costruttivi sofisticati. La struttura delle poltroncine Ortigia S.H. è interamente realizzata in massello di noce canaletto o frassino, con tecniche di lavorazione che rimandano alla tradizione dell'ebanisteria italiana. La seduta imbottita può essere rivestita in pelle o tessuto, mentre lo schienale è realizzato interamente in cuoio ed è caratterizzato nella parte posteriore da raffinate cuciture. Le poltroncine Ortigia S.H. grazie alle loro proporzioni contenute e alla loro eleganza senza tempo si inseriscono armoniosamente in qualsiasi ambiente della casa, dalla camera da letto allo spazio living, in abbinamento a tutti i divani della collezione Flexform.

*Ortigia S.H. is the name of a family of seating pieces distinguished by traditional charm, updated with contemporary flair and finished with sophisticated construction details. The structure of the Ortigia S.H. small armchairs is made entirely of solid Canaletto walnut or ash, artisan-crafted with techniques that trace back to the tradition of fine Italian cabinetmaking. The seat can be upholstered in leather or fabric, while the backrest is made entirely of cowhide and features elegant top stitching on the back. Thanks to their compact proportions and timeless elegance, the Ortigia S.H. small armchairs are equally at home in any setting, from the bedroom to the living room, and can be paired with any of the sofas in the Flexform collection.*





**Ortigia S.H.**  
Design Center





**Ortigia S.H.**  
Design Center









**Ortigia S.H.**  
Design Center





# Ortigia S.H. Data Sheet

Design Center

## Struttura

in legno massello di noce canaletto nelle finiture naturale, tinto extra, tinto caffè o massello di frassino nelle finiture naturale, tinto noce, tinto ciliegio, tinto teak, tinto caffè, tinto wengé, tinto ebano, tinto marrone

## Schienale e braccioli

rivestiti in cuoio nei colori: bianco (5007), grigio (5003), testa di moro (5004), testa di moro scuro (5013), nero (5005), oliva (5006), rosso bulgaro (5008), sabbia (5001), tabacco (5015)

## Seduta

in legno multistrato con imbottitura in poliuretano espanso rivestito in tessuto protettivo accoppiato

## Piedi

in zama pressofusa nelle finiture satinato, cromato, brunito, cromo nero, canna di fucile. Appoggio a terra su puntali in materiale termoplastico

## Rivestimento seduta

sfoderabile sia nella versione in tessuto che nella versione in pelle

## Structure

*in solid Canaletto walnut with natural finish, stained Canaletto walnut extra or coffee; or, in solid ash with natural finish or stained walnut, cherry, teak, coffee, wenge, ebony or brown*

## Backrest and armrests

*upholstered in cowhide in the following colors: white (5007), grey (5003), dark brown (5004), extra dark brown (5013), black (5005), olive (5006), Bulgarian red (5008), sand (5001), tobacco (5015)*

## Seat

*in plywood with polyurethane foam padding, covered with a protective laminated fabric*

## Feet

*in die-cast zama with satin, chrome, burnished, black chrome or gun metal finish. Rests on tips made of thermoplastic material*

## Upholstery

*is removable in both the fabric and leather versions*

25613/25614

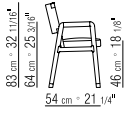

25623/25624

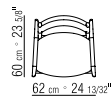
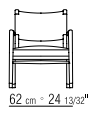
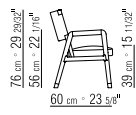

25633/25634

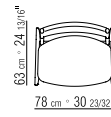

# Echoes | Echoes S.H.

Christophe Pillet



ARMCHAIRS  
OTTOMANS  
CHAISE LONGUES  
DAYBEDS  
DINING CHAIRS  
DINING ARMCHAIRS  
BAR STOOLS

Il progetto della famiglia di sedute Echoes è frutto di una sensibilità matura che si nutre di stimoli e fonti di ispirazione differenti: la tradizione della scuola scandinava incontra quella mediterranea, lo stile rustico incrocia quello urbano, il design della memoria è comunque calato nella realtà del presente e proiettato nel futuro. La struttura delle sedute manifesta una linea essenziale ed è realizzata in rigoroso metallo, mentre seduta e schienale sono caratterizzati da un fine intreccio in cordoncino di carta o paglia di fiume, una lavorazione all'apparenza semplice e tuttavia complessa, ancora oggi interamente realizzata a mano.

Una differente interpretazione stilistica è quella offerta dalla poltrona Echoes S.H. che vede abbinato alla struttura in metallo il cuoio: un accostamento semplice ma di sicuro effetto e in grado di garantire un elevato livello di confort, grazie alla conformazione ergonomica della seduta e dello schienale.

La famiglia Echoes comprende poltrone con e senza braccioli che possono essere corredate anche dal poggiatesta coordinato, sedie e poltroncine da pranzo, sgabelli e anche una snella chaise longue, tutte accomunate da linee pure e proporzioni misurate che consentono a questi elementi di inserirsi facilmente in ogni ambiente della casa, da soli oppure in abbinamento a tutti i divani della collezione Flexform.

*The design project for the Echoes family of seating grew out of a mature awareness nourished by different ideas and inspirations.*

*The traditional Scandinavian school meets Mediterranean style; rustic and urban styles cross paths. The design of memory is, in any case, living in the present and projected into the future.*

*The sleek metal structure contrasts with the pliable seat and backrest made of fine woven paper cord or paper rush cord. This seemingly simple process is actually quite complex and still today performed entirely by hand.*

*A different stylistic interpretation is expressed by the Echoes S.H. armchair that pairs the metal structure with cowhide: a classic, eye-catching combination but one that, thanks to the ergonomic contours of the seat and backrest, also ensures the utmost in comfort. The Echoes family includes armchairs with and without armrests that coordinate nicely with matching footstools, chairs and dining chairs, stools and a slender chaise longue. All share the same pure lines and understated proportions that allow these pieces to be equally at home in any room in the house, alone or paired with the sofas in the Flexform collection.*







**Echoes | Echoes S.H.**  
Christophe Pillet







**Echoes S.H.**  
Christophe Pillet









**Echoes | Echoes S.H.**  
Christophe Pillet



**Echoes | Echoes S.H.**  
Christophe Pillet







**Echoes S.H.**  
Christophe Pillet





**Echoes S.H.**  
Christophe Pillet







**Echoes | Echoes S.H.**  
Christophe Pillet







# Echoes S.H. Data Sheet

Christophe Pillet

## Struttura

in metallo brunito, canna di fucile  
o nel colore bianco 100

## Struttura versione Finish Plus

in metallo satinato, cromato,  
cromo nero

## Bracciolo

in metallo brunito, canna di fucile o bianco  
100 con inserto in legno nelle finiture noce  
canaletto naturale, tinto extra, tinto caffè o  
frassino naturale, tinto noce, tinto ciliegio,  
tinto teak, tinto colore caffè, tinto wengé,  
tinto ebano, tinto marrone

## Bracciolo versione Finish Plus

in metallo satinato, cromato, cromo nero con  
inserto in legno nelle finiture noce canaletto  
nelle finiture naturale, tinto extra, tinto caffè  
o frassino nelle finiture naturale, tinto noce,  
tinto ciliegio, tinto teak, tinto caffè, tinto  
wengé, tinto ebano, tinto marrone

## Seduta / Schienale

in fibra di vetro e poliuretano espanso rivestita  
in cuoio nei colori: bianco (5007), grigio  
(5003), testa di moro (5004), testa di moro  
scuro (5013), nero (5005), oliva (5006), rosso  
bulgaro (5008), sabbia (5001), tabacco (5015)

## Cuscino seduta poltrona

in poliuretano espanso e fibra  
di poliestere. A richiesta  
con supplemento di prezzo

## Rivestimento cuscino di seduta poltrona

sfoderabile sia nella versione in tessuto  
che nella versione in pelle

## Piedi

appoggio a terra su puntali in materiale  
termoplastico

## Structure

in metal with burnished or gun metal finish,  
or in white 100

## Structure Finish Plus version

in metal with satin, chrome or black  
chrome finish

## Armrest

in metal, with burnished, gun metal  
or white 100 finish, with wood insert in the  
following: Canaletto walnut with natural  
finish, or stained Canaletto walnut extra  
or coffee; or, in ash with natural finish  
or stained walnut, cherry, teak, coffee,  
wenge, ebony or brown

## Armrest Finish Plus version

in metal with satin, chrome or black chrome  
finish, with wood insert in Canaletto walnut  
with natural finish, or stained Canaletto  
walnut extra or coffee; or, in ash with natural  
finish or stained walnut, cherry, teak,  
coffee, wenge, ebony or brown

## Seat / Backrest

in fiberglass and polyurethane foam  
upholstered in cowhide in the following  
colors: white (5007), grey (5003),  
dark brown (5004), extra dark brown (5013),  
black (5005), olive (5006), Bulgarian red  
(5008), sand (5001), tobacco (5015)

## Armchair seat cushion

in polyurethane foam and polyester fiber.  
Upon request, with upcharge

## Seat cushion upholstery

is removable in both the fabric and leather  
versions

## Feet

rest on tips made of thermoplastic material

28003



28007

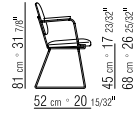

28023



28027



28033

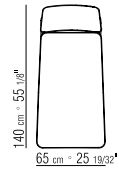
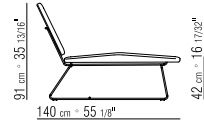

28052

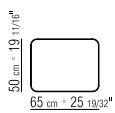

28062

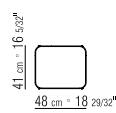

28068



# Echoes Data Sheet

Christophe Pillet

## Struttura

in metallo brunito, canna di fucile o nel colore bianco 100

## Struttura versione Finish Plus

in metallo satinato, cromato, cromo nero

## Bracciolo

in metallo brunito, canna di fucile o bianco 100 con inserto in legno nelle finiture noce canaletto naturale, tinto extra, tinto caffè o frassino nelle finiture naturale, tinto noce, tinto ciliegio, tinto teak, tinto caffè, tinto wengé, tinto ebano, tinto marrone

## Bracciolo versione Finish Plus

in metallo satinato, cromato, cromo nero con inserto in legno nelle finiture noce canaletto naturale, tinto extra, tinto caffè o frassino nelle finiture naturale, tinto noce, tinto ciliegio, tinto teak, tinto caffè, tinto wengé, tinto ebano, tinto marrone

## Seduta / Schienale

in metallo con intreccio in paglia di fiume o in cordoncino in carta di pura cellulosa nei colori naturale 4002, antracite 4005

## Cuscino seduta poltrona

in poliuretano espanso e fibra di poliestere. A richiesta con supplemento di prezzo

## Rivestimento cuscino di seduta poltrona

sfoderabile sia nella versione in tessuto che nella versione in pelle

## Piedi

appoggio a terra su puntali in materiale termoplastico

## Structure

in metal with burnished or gun metal finish, or in white 100

## Finish Plus version structure

in metal with satin, chrome or black chrome finish

## Armrest

in metal with burnished, gun metal or white 100 finish, with wood insert in the following: Canaletto walnut with natural finish, or stained Canaletto walnut extra or coffee; or, in ash with natural finish or stained walnut, cherry, teak, coffee, wenge, ebony or brown

## Finish Plus Armrest version

in metal with satin, chrome or black chrome finish, with wood insert in Canaletto walnut with natural finish, or stained Canaletto walnut extra or coffee; or, in ash with natural finish or stained walnut, cherry, teak, coffee, wenge, ebony or brown

## Seat / Backrest

in metal with woven paper rush cord; or, in pure cellulose paper cord, in natural 4002 or anthracite 4005 color

## Armchair seat cushion

in polyurethane foam and polyester fiber. Upon request, with upcharge

## Seat cushion upholstery

is removable in both the fabric and leather versions

## Feet

rest on tips made of thermoplastic material



28001 / 28002



28005 / 28006

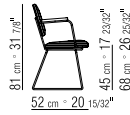

28021 / 28022



28099



28025 / 28026

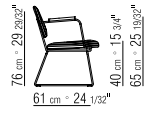

28031 / 28032

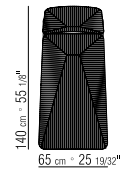
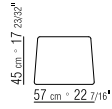
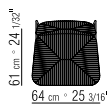
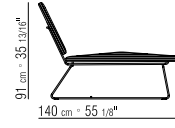

28050 / 28051

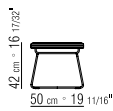

28060 / 28061



28066 / 28067

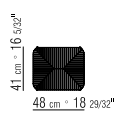
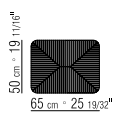
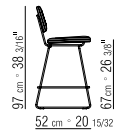

# Fly

Antonio Citterio

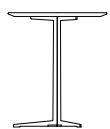

DINING TABLES

L'ampia e versatile famiglia di tavoli, tavolini e contenitori Fly vede l'inserimento di un tavolo dalle misure particolari, pensato per una precisa funzione di utilizzo.

Espressamente progettato in abbinamento agli sgabelli della collezione Flexform, il nuovo tavolo Fly è alto cm 93 mentre il piano è previsto nella misura diametro 80. La struttura del tavolo è in metallo nelle finiture satinato, cromato, cromo nero, brunito e color canna di fucile.

I piani possono essere realizzati nelle versioni in legno impiallacciato in noce canaletto e frassino in numerose tinte, laccato lucido in un'ampia gamma cromatica o in diverse varietà di pregiato marmo. Grazie al suo disegno essenziale e alla pluralità di finiture disponibili, il tavolo Fly si inserisce con facilità negli ambienti domestici così come in spazi hospitality.

*The extensive, versatile family of Fly tables, coffee/side tables and cabinets expands to include a specially-sized table, designed for a specific function and use. Custom-designed to be paired with the bar stools in the Flexform collection, the new Fly table is 93 cm high and the top measures 80 in diameter.*

*The table's metal structure comes in satin, chrome, black chrome, burnished and in gunmetal grey. The tops come in versions with Canaletto walnut or ash veneer in a number of shades; with glossy lacquer finish in a wide palette of colors; or in various types of luxurious marble.*

*Thanks to its uncluttered design and the number of available finishes, the Fly table is a stylish fit in homes as well as hospitality spaces.*







**Fly**  
Antonio Citterio



**Fly**  
Antonio Citterio







# Fly

## Data Sheet

Antonio Citterio

### Struttura

in metallo satinato, cromato, brunito, cromo nero, canna di fucile; appoggio a terra su puntali in materiale termoplastico

### Piano

in legno impiallacciato di noce canaletto nelle finiture naturale, tinto extra, tinto caffè'o legno impiallacciato di frassino nelle finiture naturale, tinto noce, tinto ciliegio, tinto teak, tinto caffè, tinto wengé, tinto ebano, tinto marrone; laccato nei colori bianco, nero, lilla, verde pino, rosa salmone, grigio verde, moka, tortora, senape, zafferano, burgundy, ottanio, grigio blu, verde muschio e mattone. Disponibili anche nella versione marmo Calacatta Oro lucido, marmo Calacatta Oro opaco, bianco Carrara lucido, nero Marquinia lucido, Emperador lucido, Emperador opaco

### Frame

*in metal with satin, chrome, burnished, black chrome or gun metal finish. Rests on tips made of thermoplastic material*

### Top

*in Canaletto walnut veneer with natural finish, or stained Canaletto walnut extra or coffee; or, in ash veneer with natural finish or stained walnut, cherry, teak, coffee, wenge, ebony or brown; or with glossy lacquer finish in white, black, lilac, pine green, salmon, grey-green, mocha, dove grey, mustard, saffron, burgundy, teal, grey-blue, moss green or brick. Also available in the following types of marble: Calacatta gold polished or matte, polished white Carrara, polished black Marquina, Emperador polished or matte*

---

14X88

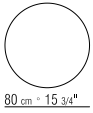
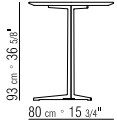



# Zefiro

Antonio Citterio

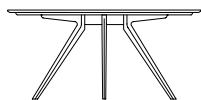

DINING TABLES

La collezione di tavoli da pranzo Zefiro si amplia attraverso l'inserimento di nuove misure per la variante con piano tondo, ora disponibile nelle versioni con diametro cm 160 e cm 190.

Caratterizzato da un segno lieve e contemporaneo, Zefiro è un tavolo estremamente versatile proprio grazie alla vasta gamma di misure e ai materiali con i quali può essere realizzato e dunque si inserisce con garbo ed eleganza negli ambienti più diversi, in abbinamento con le numerose sedie e poltroncine della collezione Flexform.

Le affusolate gambe in alluminio pressofuso sono proposte nelle finiture satinato, cromato, cromo nero, brunito, color canna di fucile, e verniciato nei colori bianco e nero. I piani sono disponibili nelle varianti tondo, quadrato, ovale e rettangolare in una pluralità di misure e possono essere realizzati nelle versioni in legno impiallacciato, laccato lucido o in diverse varietà di pregiato marmo.

Il tavolo tondo nelle misure diametro cm 160 e 190 è previsto unicamente nelle versioni impiallacciato in noce canaletto o frassino in molteplici tinte oppure laccato lucido in una palette di raffinate cromie.

*The collection of Zefiro dining tables expands with the addition of new sizes for the round-top table, now available in 160 cm and 190 cm diameters.*

*Featuring a light, contemporary look, Zefiro is extremely versatile, thanks to the wide range of sizes and materials in which it can be crafted, making it a table that can confidently and stylishly furnish any setting and be paired seamlessly with the many chairs and dining chairs in the Flexform collection.*

*The tapered cast-aluminum legs come in satin, chrome, black chrome, burnished and gunmetal grey finish, or painted black or white.*

*The tops are available in round, square, oval and rectangular shape in a number of different sizes and can be crafted in veneered wood, in glossy lacquer finish, or in various types of luxurious marble.*

*The round table in the 160 cm and 190 cm diameters is available only in Canaletto walnut or ash veneer in a selection of different shades, or with glossy lacquer finish in a sophisticated palette of colors.*









**Zefiro**  
Antonio Citterio





**Zefiro**  
Antonio Citterio



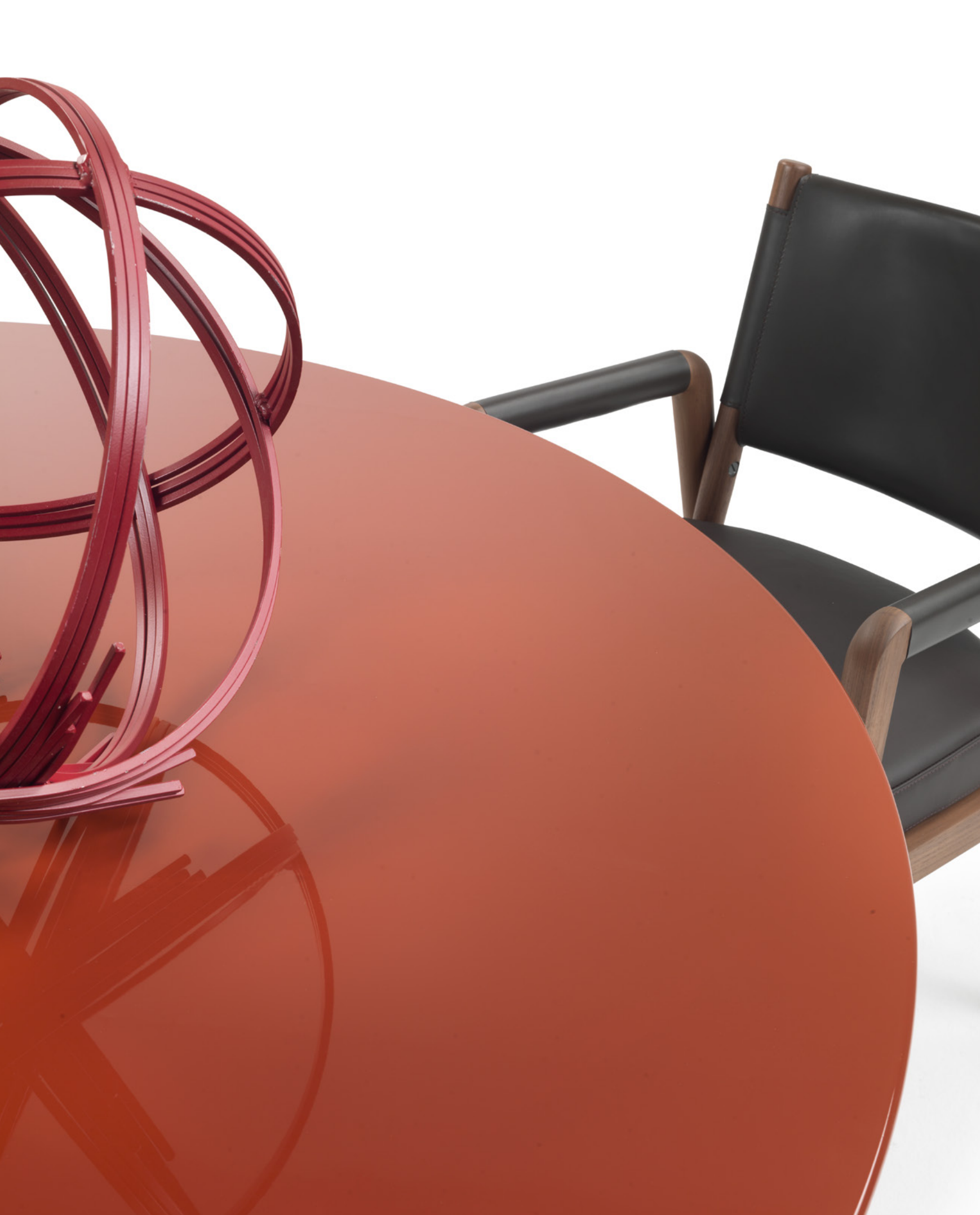

# Zefiro

## Data Sheet

Antonio Citterio

### Struttura

in metallo satinato, cromato, brunito, cromo nero, canna di fucile, bianco 100, nero 900. Appoggio a terra su puntali in materiale termoplastico

### Piano

in legno impiallacciato di noce canaletto nelle finiture naturale, tinto extra, tinto caffè o legno impiallacciato di frassino nelle finiture naturale, tinto noce, tinto ciliegio, tinto teak, tinto caffè, tinto wengé, tinto ebano, tinto marrone; laccato nei colori bianco, nero, lilla, verde pino, rosa salmone, grigio verde, moka, tortora, senape, zafferano, burgundy, ottanio, grigio blu, verde muschio e mattone.

### Frame

*in metal with satin, chrome, burnished, black chrome, gun metal finish, white 100 or black 900.  
Rests on tips made of thermoplastic material*

### Top

*in Canaletto walnut veneer with natural finish, or stained Canaletto walnut extra or coffee; or, in ash veneer with natural finish or stained walnut, cherry, teak, coffee, wenge, ebony or brown; or with lacquer finish in white, black, lilac, pine green, salmon, grey-green, mocha, dove grey, mustard, saffron, burgundy, teal, grey-blue, moss green or brick*



23883

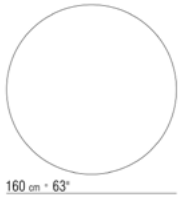
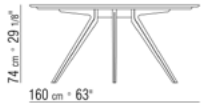

23884

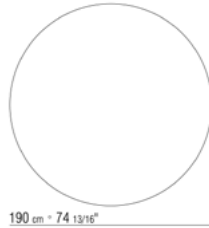
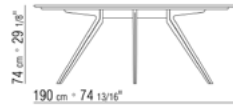

# Asolo

Antonio Citterio

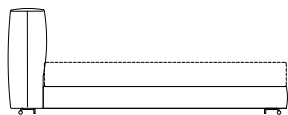

BEDS

Accogliente e raffinato al tempo stesso, il letto Asolo ripropone i canoni estetici dell'omonimo sistema di sedute.

Il letto Asolo è connotato da imbottiture generose ed il rivestimento è interamente sfoderabile.

La testata è proposta in due diverse profondità ed è caratterizzata da un'originale piega, un elegante dettaglio di confezione che dimostra come l'attitudine sartoriale sia insita nel patrimonio genetico dell'azienda. Il letto Asolo poggia su un'essenziale base in metallo, è disponibile in una pluralità di misure e in diverse varianti: con base costituita dal solo giroletto, base rigida, base con pianale a doghe regolabile in altezza e base con vano contenitore, utile per riporre cuscini, coperte e biancheria.

Asolo veste con disinvoltura tutti i tessuti e le pelli dell'ampia collezione Flexform e si inserisce con misurata eleganza negli ambienti più diversi.

*Comfortable and sophisticated, the Asolo bed reflects the same aesthetic concepts as the eponymous seating system.*

*The Asolo bed is generously padded and its upholstery is completely removable.*

*The headboard comes in two different depths and features a unique fold-over design, an elegant construction detail that clearly indicates how the talent for tailoring is an integral part of the company's DNA.*

*The Asolo bed rests on a sleek metal base and comes in a number of sizes and different variations: with base composed of a single perimeter frame; rigid base; platform base with height-adjustable slats; and base with storage compartment, handy for storing pillows, blankets and bed linens.*

*Asolo is equally at ease when 'dressed' in any of the fabrics or leathers from the vast Flexform collection and brings understated elegance to the most diverse decors.*



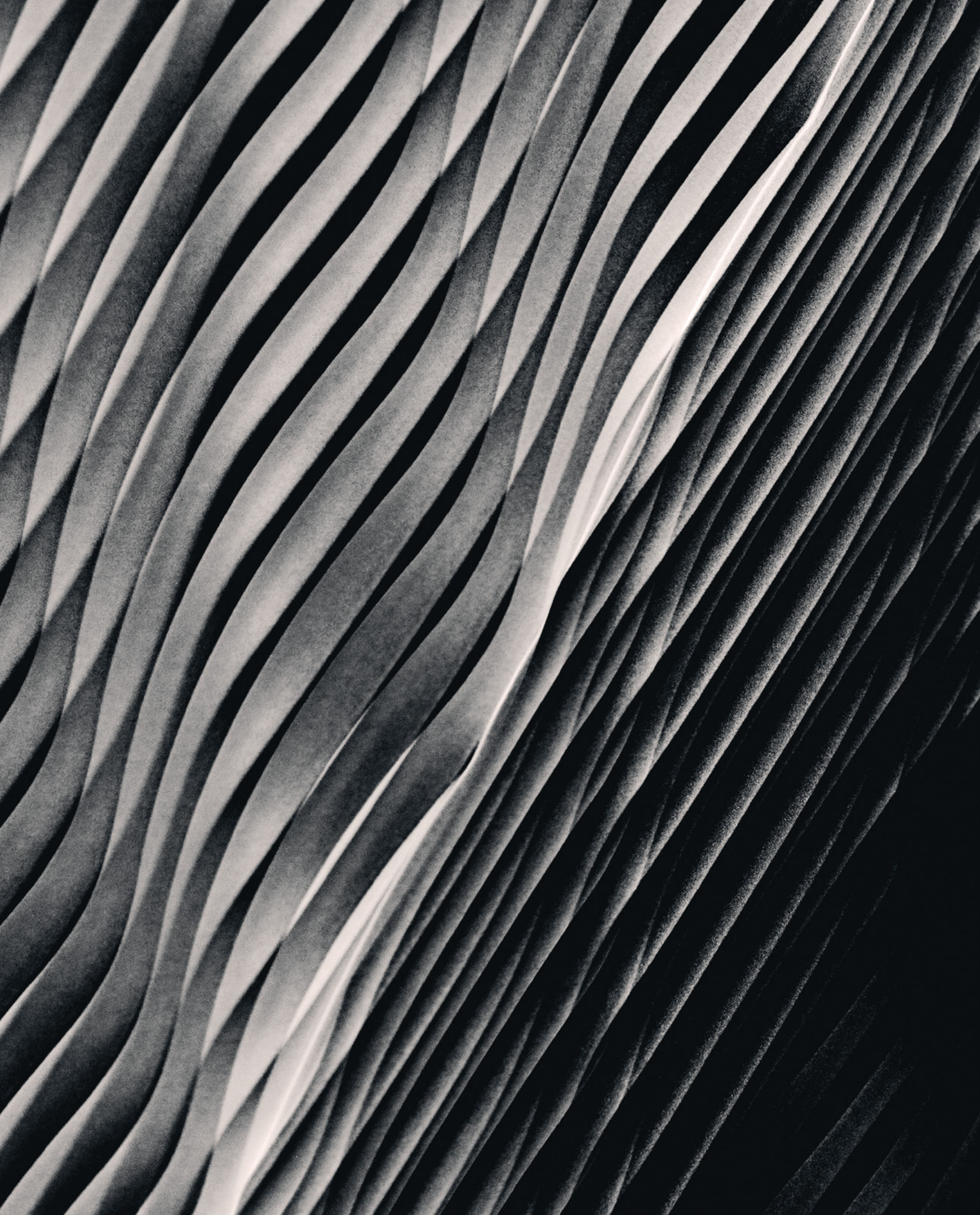







**Asolo**  
Antonio Citterio



**A solo**  
Antonio Citterio









**Asolo**  
Antonio Citterio





# Asolo

## Data Sheet

Antonio Citterio

### Base rigida

in legno multistrato con imbottitura in poliuretano espanso rivestito in tessuto protettivo accoppiato

### Base contenitore

apribile con pianale in metallo con doghe in legno giroletto in legno multistrato con imbottitura in poliuretano espanso rivestita in tessuto protettivo accoppiato

### Base con pianale in metallo con doghe in legno

regolabile in quattro diverse posizioni di altezza della rete: 1° 4,5 cm, 2° 7,3 cm, 3° 9,5 cm, 4° 12,6 cm, verificare la misura utile d'appoggio della rete all'interno del letto come da disegno

### Giroletto

in legno multistrato con imbottitura in poliuretano espanso rivestita in tessuto protettivo accoppiato

### Testata

in metallo con imbottitura in poliuretano stampato e fibra di poliestere rivestita in tessuto protettivo accoppiato

### Piedi

tubolare in metallo verniciato a forno con polveri epossidiche

### Rivestimento

sfoderabile sia nella versione in tessuto che nella versione in pelle

### Rigid base

*in plywood with polyurethane foam padding, covered with a protective laminated fabric*

### Storage base

*that opens, metal platform with wood slats. Bedframe in plywood with polyurethane foam padding, covered with a protective laminated fabric*

### Base with metal platform and wood slats

*adjustable to four height positions: 1st 4.5 cm, 2nd 7.3 cm, 3rd 9.5 cm, 4th 12.6 cm; double-check there is sufficient space to support the platform inside the bed, as shown in the figure*

### Bedframe

*in plywood with polyurethane foam padding, covered with a protective laminated fabric*

### Headboard

*in metal with molded polyurethane and polyester fiber padding, covered with a protective laminated fabric*

### Feet

*in tubular metal with epoxy powder-coat finish*

### Upholstery

*is removable in both the fabric and leather versions*



BASE RIGIDA CON PIANALE IN LEGNO  
BASE IN WOOD

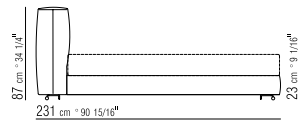

270L1

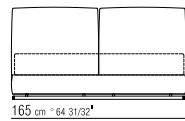

270L2

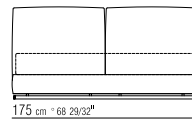

270L3

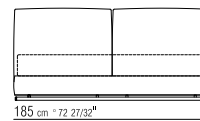

270L5

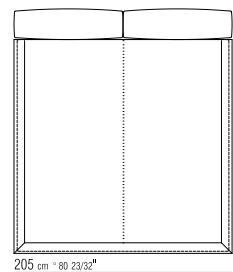
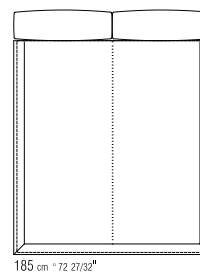
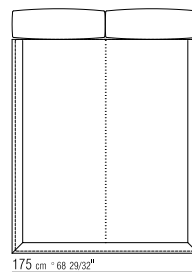
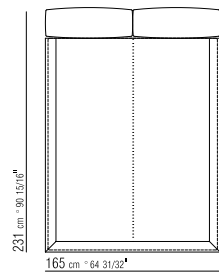
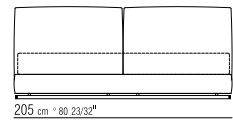

BASE CON PIANALE A DOGHE | BASE WITH  
PLATFORM FITTED WITH WOODEN SLATS

270M1

270M2

270M3

270M5

BASE CONTENITORE APRIBILE CON PIANALE  
A DOGHE | STORAGE BASE WITH PLATFORM  
FITTED WITH WOODEN SLATS

270N1

270N2

270N3

270N5

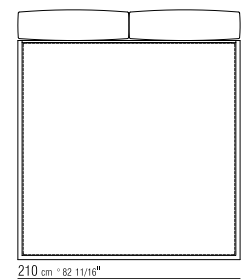
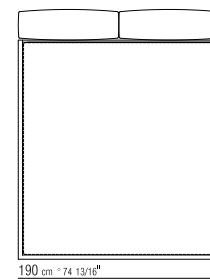
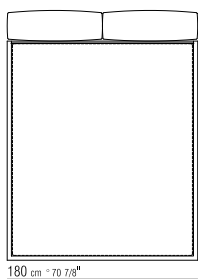
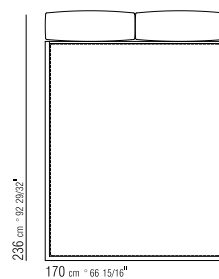
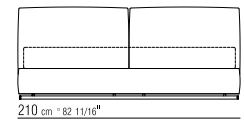
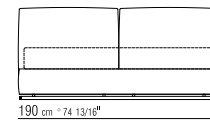
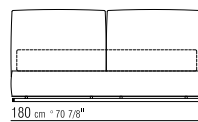
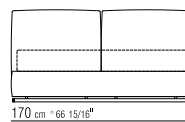
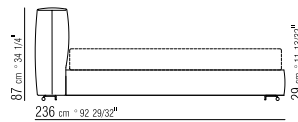

**Asolo**  
Antonio Citterio

BASE CON PIANALE A DOGHE | BASE WITH PLATFORM FITTED WITH WOODEN SLATS

270M6

270M8

BASE CONTENITORE APRIBILE CON PIANALE A DOGHE | STORAGE BASE WITH PLATFORM FITTED WITH WOODEN SLATS

270N6

270N8

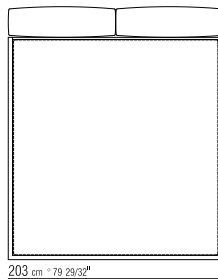
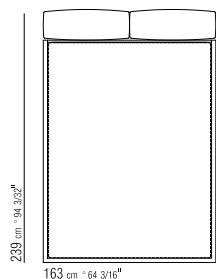
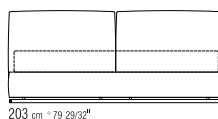
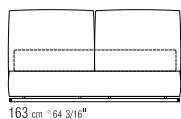
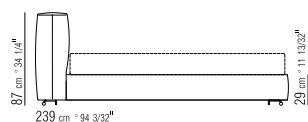

BASE RIGIDA CON PIANALE IN LEGNO  
BASE IN WOOD

270P1

270P2

270P3

270P5

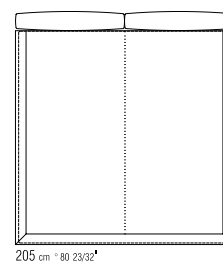
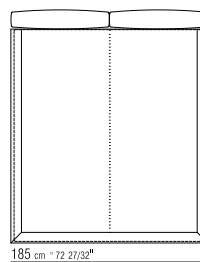
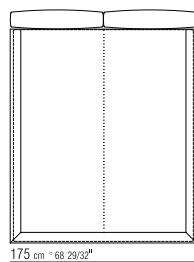
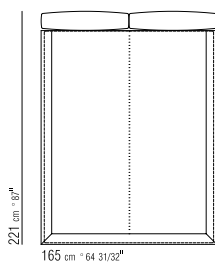
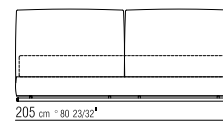
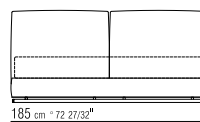
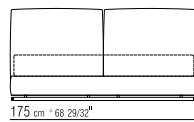
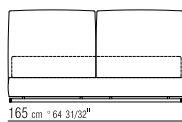
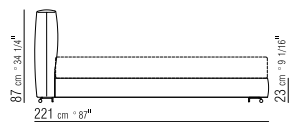

BASE CON PIANALE A DOGHE | BASE WITH PLATFORM FITTED WITH WOODEN SLATS

270Q1

270Q2

270Q3

270Q5

BASE CONTENITORE APRIBILE CON PIANALE A DOGHE | STORAGE BASE WITH PLATFORM FITTED WITH WOODEN SLATS

270R1

270R2

270R3

270R5

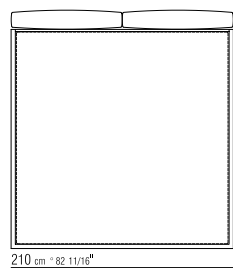
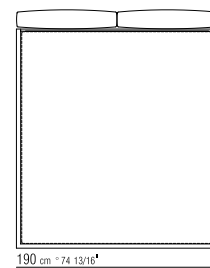
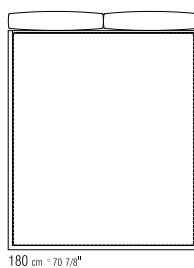
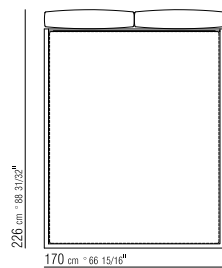
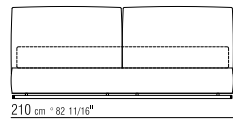
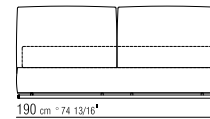
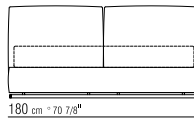
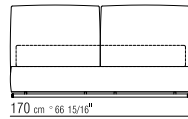
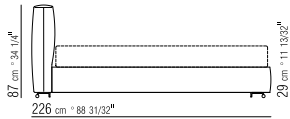

BASE CON PIANALE A DOGHE | BASE WITH PLATFORM FITTED WITH WOODEN SLATS

270Q6

270Q8

BASE CONTENITORE APRIBILE CON PIANALE A DOGHE | STORAGE BASE WITH PLATFORM FITTED WITH WOODEN SLATS

270R6

270R8

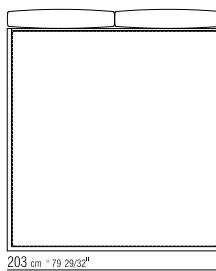
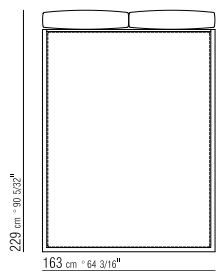
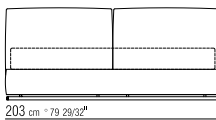
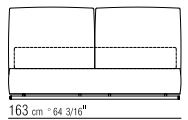
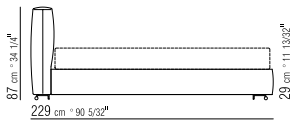



**Asole**  
Antonio Citterio

BASE FORNITA SENZA RETE  
BED FRAME ONLY

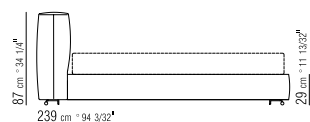

270VA

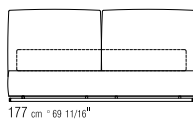

270VC

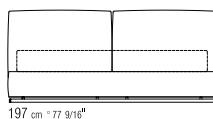

270VE

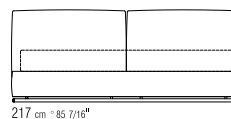

239 cm - 94 3/32"

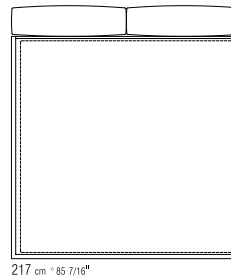
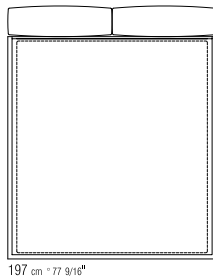
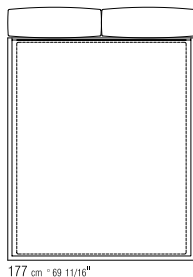

BASE FORNITA SENZA RETE  
BED FRAME ONLY

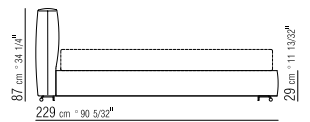

270YA

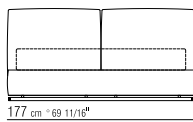

270YC

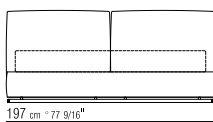

270YE

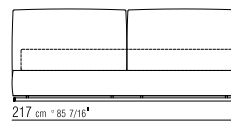

229 cm - 90 5/32"

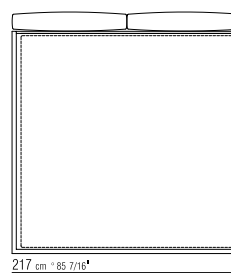
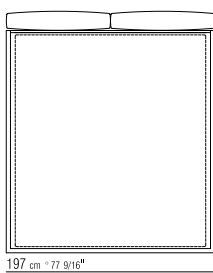
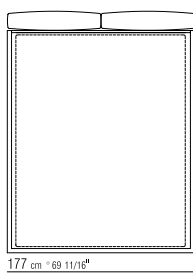



# Mate

Christophe Pillet



ARMCHAIRS  
OTTOMANS  
BOOKSHELVES  
CABINETS  
ACCESSORIES

Mate è un oggetto dal carattere singolare, utilizzabile sia come piano d'appoggio sia come portariviste.

All'essenziale struttura in metallo fa da contrappunto la parte superiore interamente realizzata in cuoio intrecciato a mano.

Versatile nel rispondere a svariate funzioni di utilizzo, Mate è un accessorio pratico ed elegante che può trovare un'ideale collocazione in ogni ambiente della casa ed essere facilmente accostato a tutte le sedute della collezione Flexform.

*Mate is an exceptional object; it can be used as a table top or as a magazine holder.*

*In contrast to the rigid metal structure, the upper part is made entirely of pliable hand-woven cowhide.*

*Flexible in serving many different uses, Mate is an elegant and practical accessory that can be ideally placed in any room in the house and confidently paired with all of the seating elements in the Flexform collection.*









**Mate**  
Christophe Pillet

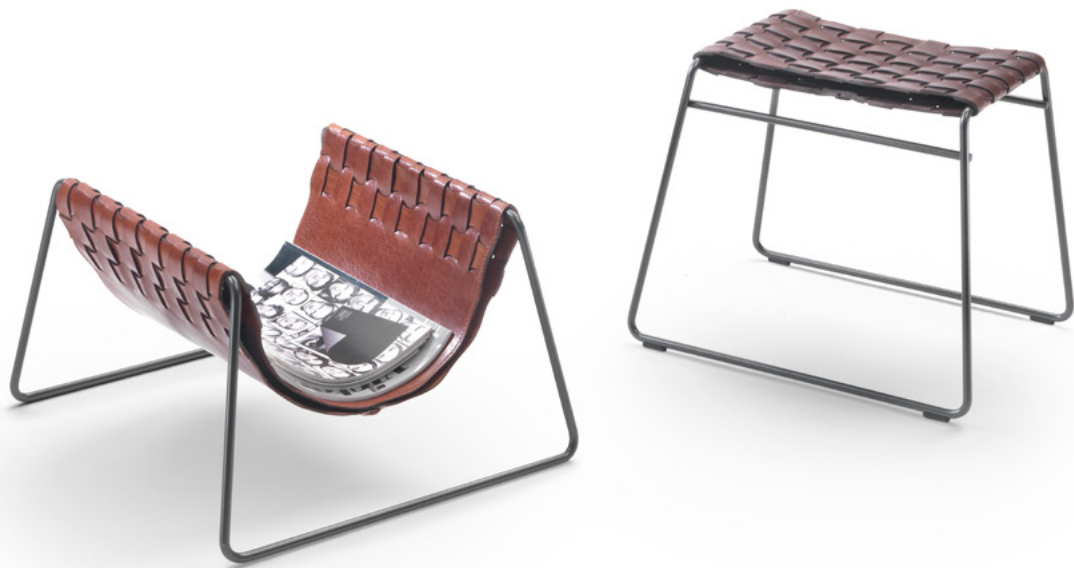



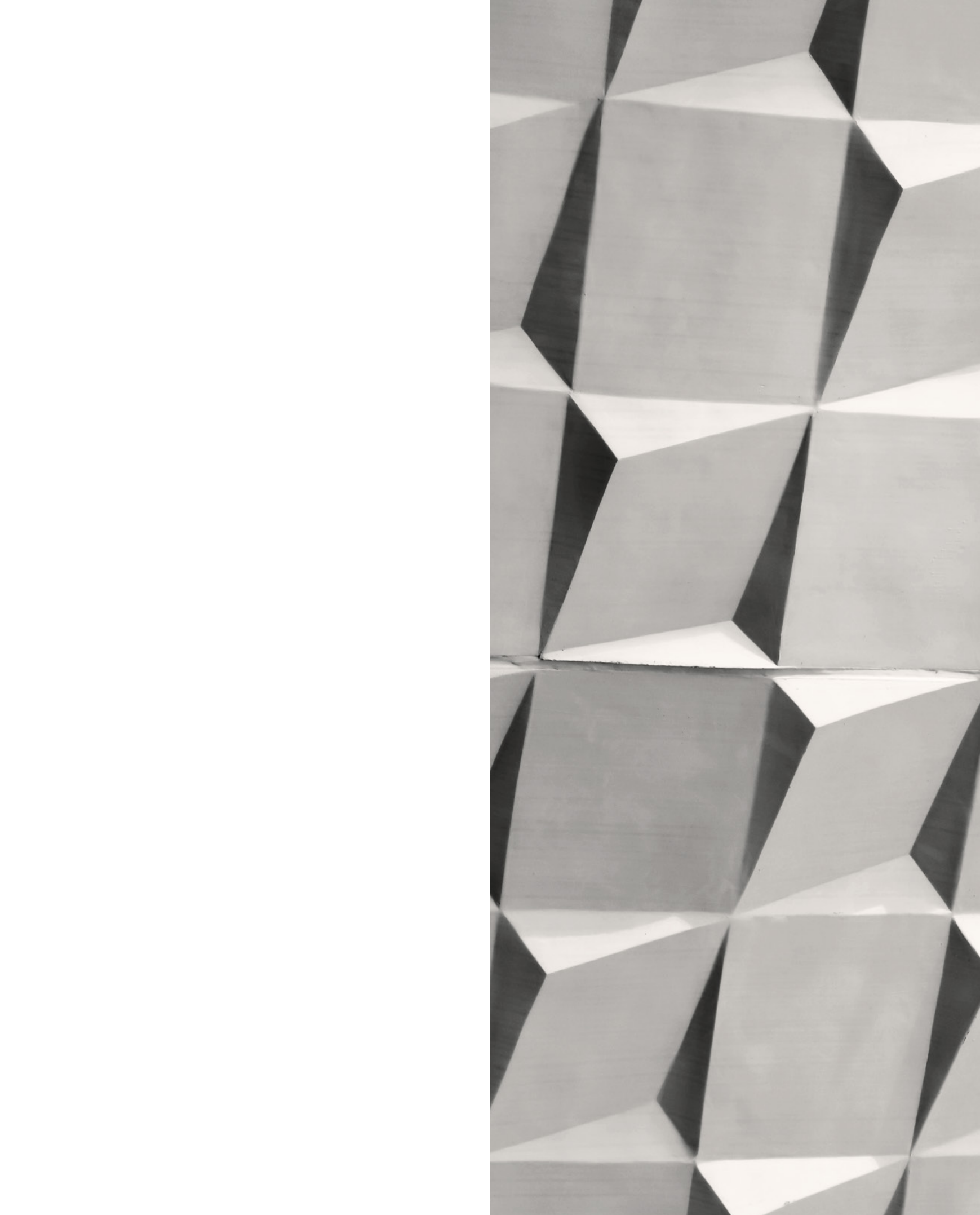

**Mate**  
Christophe Pillet



# Mate Data Sheet

Christophe Pillet

## Struttura

in metallo satinato, cromato, brunito, cromo nero, canna di fucile o nel colore bianco 100. Intreccio in cuoio nei colori: nero (5005), tabacco (5015), testa di moro (5004), testa di moro scuro (5013)

## Piedi

appoggio a terra su puntali in materiale termoplastico

## Structure

*in metal with satin, chrome, burnished, black chrome, or gun metal finish, or in white 100. Woven cowhide in the following colors: black (5005), tobacco (5015), dark brown (5004), extra dark brown (5013)*

## Feet

*rest on tips made of thermoplastic material*



---

29250

29260

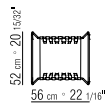
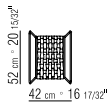
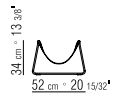

# Berry

Design Center



DINING TABLES  
COFFEE TABLES  
SIDE TABLES  
CONSOLES

La leggerezza della base in metallo, caratterizzata da un disegno minimale, conferisce un appeal contemporaneo alla famiglia di tavoli da pranzo e tavolini Berry. L'aerea struttura è costituita da sottili bacchette in metallo ed è proposta nelle finiture satinato, cromato, cromo nero, brunito e color canna di fucile.

Numerose ed originali le combinazioni che si possono ottenere con le finiture dei piani disponibili per il tavolo da pranzo il cui piano dallo spessore considerevole è previsto nelle versioni impiallacciato in noce canaletto o frassino in molteplici tinte oppure laccato lucido in una palette di raffinate cromie. I tavolini Berry sono invece proposti nelle versioni con piano in massello di cedro del Libano finitura naturale oppure in gres ceramico, un materiale composito dall'eccellente resistenza all'usura, alle abrasioni e alle macchie.

*The airy lightness of the metal base and its minimalist design lend contemporary appeal to the Berry family of dining tables and coffee/side tables.*

*The see-through structure is composed of slender metal rods and is available with satin, chrome, black chrome, burnished and gunmetal grey finish.*

*Many unique combinations can be achieved with the finishes available for the dining table.*

*Its impressively thick top comes in Canaletto walnut or ash veneer, in an array of different shades, or with glossy lacquer finish in a sophisticated palette of colors.*

*The Berry coffee and side tables come with top in solid cedar of Lebanon with natural finish,*

*or in ceramic stoneware, a composite material with excellent resistance to wear, scratches and stains.*





**Berry**  
Design Center





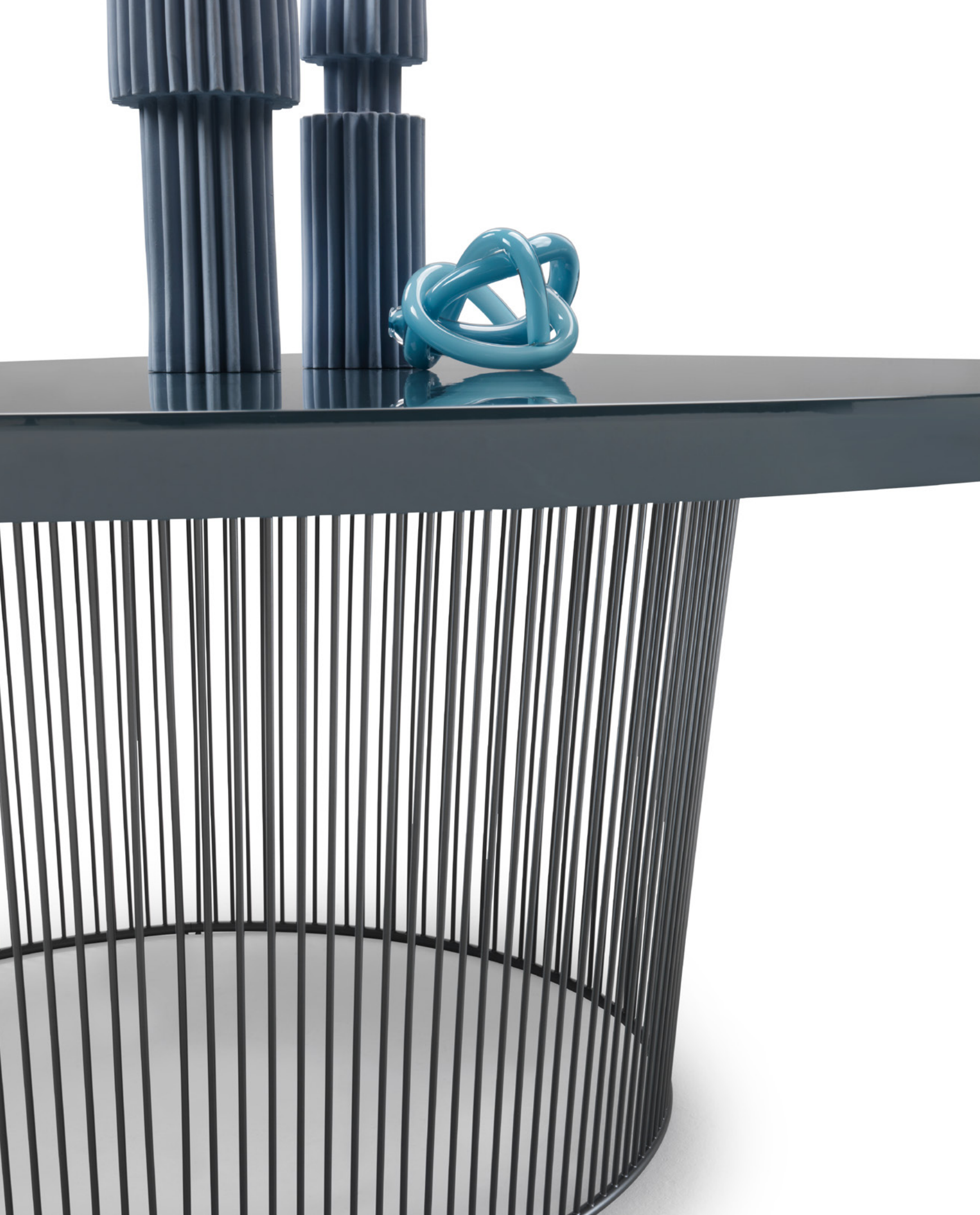



**Berry**  
Design Center

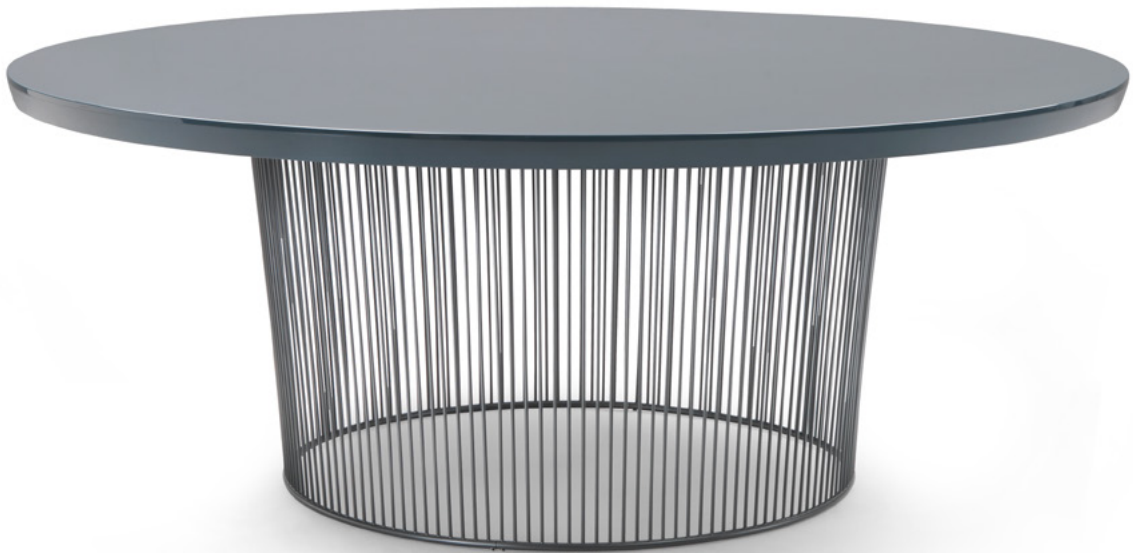

**Berry**  
Design Center









**Berry**  
Design Center



**Berry**  
Design Center







# Berry

## Data Sheet

Design Center

### Struttura

in metallo nelle finiture satinato, cromato, brunito, cromo nero, canna di fucile. Poggia a terra su puntali in materiale termoplastico

### Piano tavolo da pranzo

in legno impiallacciato di noce canaletto nelle finiture naturale, tinto extra, tinto caffè o legno impiallacciato di frassino nelle finiture naturale, tinto noce, tinto ciliegio, tinto teak, tinto caffè, tinto wengé, tinto ebano, tinto marrone; laccato nei colori bianco, nero, lilla, verde pino, rosa salmone, grigio verde, moka, tortora, senape, zafferano, burgundy, ottanio, grigio blu, verde muschio e mattone

### Piano tavolino

in legno massello di cedro; in ceramica nei colori avena, ostrica, grigio blu, verde muschio e mattone

### Structure

*in metal with satin, chrome, burnished, black chrome or gun metal finish. Rests on tips made of thermoplastic material*

### Dining table top

*in Canaletto walnut veneer with natural finish, or stained Canaletto walnut extra or coffee; or, in ash veneer with natural finish or stained walnut, cherry, teak, coffee, wenge, ebony or brown; or with lacquer finish in white, black, lilac, pine green, salmon, grey-green, mocha, dove grey, mustard, saffron, burgundy, teal, grey-blue, moss green or brick*

### Coffee table top

*in solid cedar; or in ceramic, in the following colors: oat, oyster, grey-blue, moss green or brick*

29180

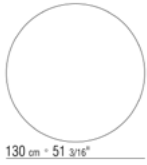
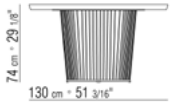

Accommodates up to 4 chairs

29181

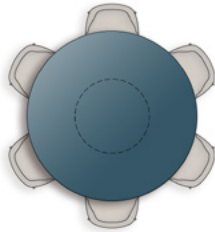
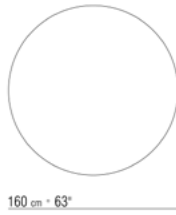
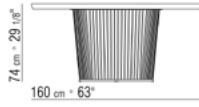

Accommodates up to 6 chairs

29182

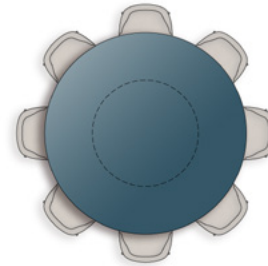
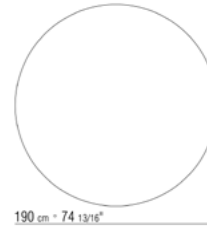
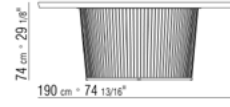

Accommodates up to 8 chairs

29170



29171

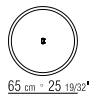



# Any Day

Christophe Pillet

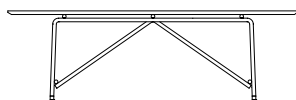

DINING TABLES  
COFFEE TABLES  
SIDE TABLES  
CONSOLES  
BOOKSHELVES  
CABINETS  
ACCESSORIES

Il pensiero alla base della famiglia di tavoli e tavolini Any Day risiede nel concetto di sottrazione.

Il designer ha volutamente ridotto il disegno all'essenziale per concentrarsi "sulla cura dei dettagli, l'esattezza delle proporzioni, la maestria nell'esecuzione, caratteristiche intrinseche che inevitabilmente definiscono la qualità di quell'oggetto".

L'idea basilare era quella di appoggiare ad una semplice struttura in metallo una parte in legno. Da questo concept sono nati dapprima tavolino e consolle e successivamente tavolo da pranzo, scrittoio ed una serie di mobili contenitori.

La struttura in metallo è caratterizzata da una linea asciutta declinata in molteplici finiture mentre i piani del tavolo da pranzo Any Day sono previsti nelle versioni impiallacciati in noce canaletto e frassino, laccati lucidi in una palette di tinte raffinate e in diverse varietà di pregiato marmo.

Lo scrittoio Any Day è corredato da pratici cassetti a scomparsa mentre la serie di contenitori Any Day è proposta in una varietà di configurazioni che rispondono a funzioni differenti e con possibilità di collocazione nei vari ambienti della casa, dall'ingresso, al soggiorno fino alla camera da letto.

Tutti gli elementi si presentano perfettamente finiti anche nella parte posteriore e possono pertanto essere utilizzati anche per suddividere gli spazi.

*The underlying concept behind the Any Day family of tables and coffee/side tables dwells in the concept of subtraction.*

*The designer intentionally stripped the design of non-essentials, to then focus on "the details, the precise proportions and masterful execution, inherent features that inescapably define the quality of that object".*

*The basic idea was to set a piece of wood on a simple metal structure. The first items to grow out of this concept were a coffee/side table and a console, followed by a dining table, desk and a series of cabinets.*

*The metal structure of the Any Day dining table has uncluttered lines and is available in many finishes, while the tops come in Canaletto walnut or ash veneer; with glossy lacquer finish in a palette of sophisticated shades; or in various types of luxurious marble.*

*The Any Day desk conceals practical invisible drawers while the series of Any Day cabinets comes in an array of configurations that satisfy many practical needs, and can be placed in different rooms in the home - from the entry to the living room and even the bedrooms.*

*All of the pieces are flawlessly finished, even on the back, so they can also be used as room dividers.*







**Any Day**  
Christophe Pillet









**Any Day**  
Christophe Pillet



**Any Day**  
Christophe Pillet









**Any Day**  
Christophe Pillet



**Any Day**  
Christophe Pillet







**Any Day**  
Christophe Pillet









**Any Day**  
Christophe Pillet



**Any Day**  
Christophe Pillet





# Any Day Data Sheet

Christophe Pillet

## Tavolo / Scrittoio

### Struttura

in metallo satinato, cromato, brunito, cromo nero, canna di fucile, bianco 100 o nella finitura laccato opaco nei colori sabbia, verde, mattone, bianco

### Piano tavolo / Tavolino

in marmo nelle tipologie Calacatta Oro lucido, Calacatta Oro opaco, bianco Carrara lucido, nero Marquina lucido, Emperador lucido, Emperador opaco o in legno impiallacciato di noce canaletto nelle finiture naturale, tinto extra, tinto caffè o di frassino nelle finiture naturale, tinto noce, tinto ciliegio, tinto teak, tinto caffè, tinto wengé, tinto ebano, tinto marrone; laccato nei colori bianco, nero, lilla, verde pino, rosa salmone, grigio verde, moka, tortora, senape, zafferano, burgundy, ottanio, grigio blu, verde muschio e mattone. L'articolo 28284 non prevede il top in marmo

### Piano scrittoio con cassetti

in legno impiallacciato di noce canaletto nelle finiture naturale, tinto extra, tinto caffè o legno impiallacciato di frassino nelle finiture naturale, tinto noce, tinto ciliegio, tinto teak, tinto caffè, tinto wengé, tinto ebano, tinto marrone

### Piedi

appoggio a terra su puntali in materiale termoplastico

## Mobile contenitore

### Struttura con cassetti

in legno impiallacciato di noce canaletto nelle finiture naturale, tinto extra, tinto caffè o legno impiallacciato di frassino nelle finiture naturale, tinto noce, tinto ciliegio, tinto teak, tinto caffè, tinto wengé, tinto ebano, tinto marrone

### Base

in metallo satinato, cromato, brunito, cromo nero, canna di fucile, bianco 100 o nella finitura opaca nei colori sabbia, verde, mattone, bianco. Appoggio a terra su puntali in materiale termoplastico

## Table / Desk

### Structure

in metal with satin, chrome, burnished, black chrome, gun metal finish or in white 100; or with matte laquered finish in sand, green, brick or white

### Table / Coffee table top

in the following types of marble: Calacatta gold polished or matte, polished white Carrara, polished black Marquina, Emperador polished or matte; or in Canaletto walnut veneer with natural finish, or stained Canaletto walnut extra or coffee; or, in ash with natural finish or stained walnut, cherry, teak, coffee, wenge, ebony or brown; or, with lacquer finish in white, black, lilac, pine green, salmon, grey-green, mocha, dove grey, mustard, saffron, burgundy, teal, grey-blue, moss green or brick. Article 28284 is not available with marble top

### Desk top with drawers

in Canaletto walnut veneer with natural finish, or stained Canaletto walnut extra or coffee; or, in ash veneer with natural finish or stained walnut, cherry, teak, coffee, wenge, ebony or brown

### Feet

rest on tips made of thermoplastic material

## Cabinet

### Structure with drawers

in Canaletto walnut veneer with natural finish, or stained Canaletto walnut extra or coffee; or, in ash veneer with natural finish or stained walnut, cherry, teak, coffee, wenge, ebony or brown

### Base

in metal with satin, chrome, burnished, black chrome or gun metal finish, or in white 100; or with matte finish in sand, green, brick or white. Rests on tips made of thermoplastic material



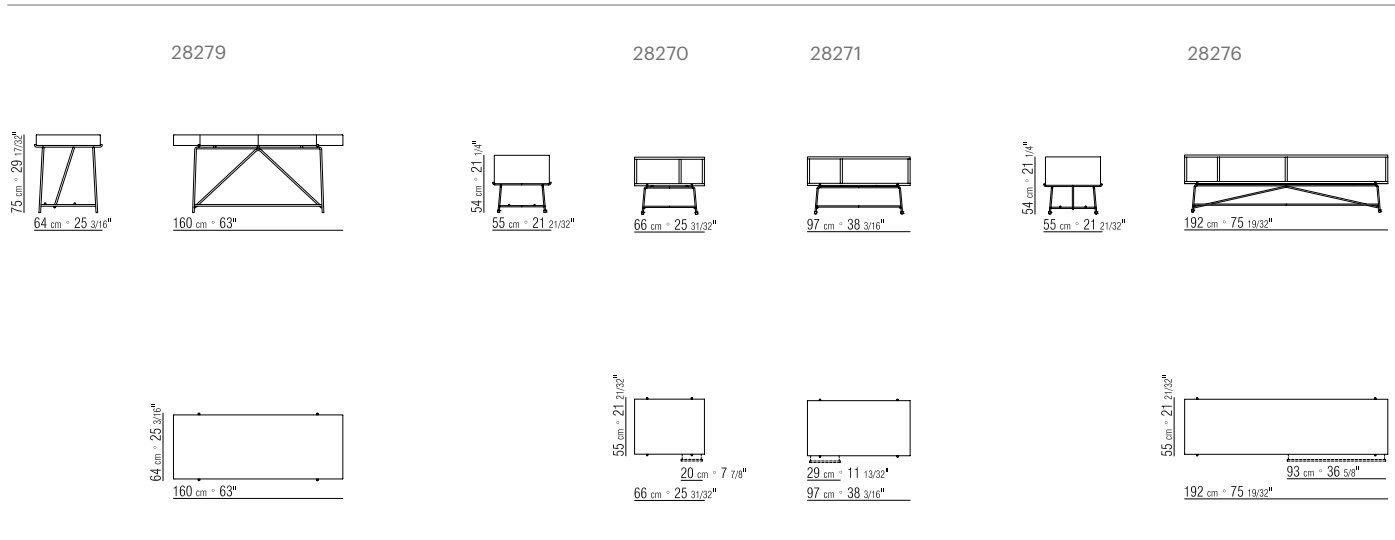
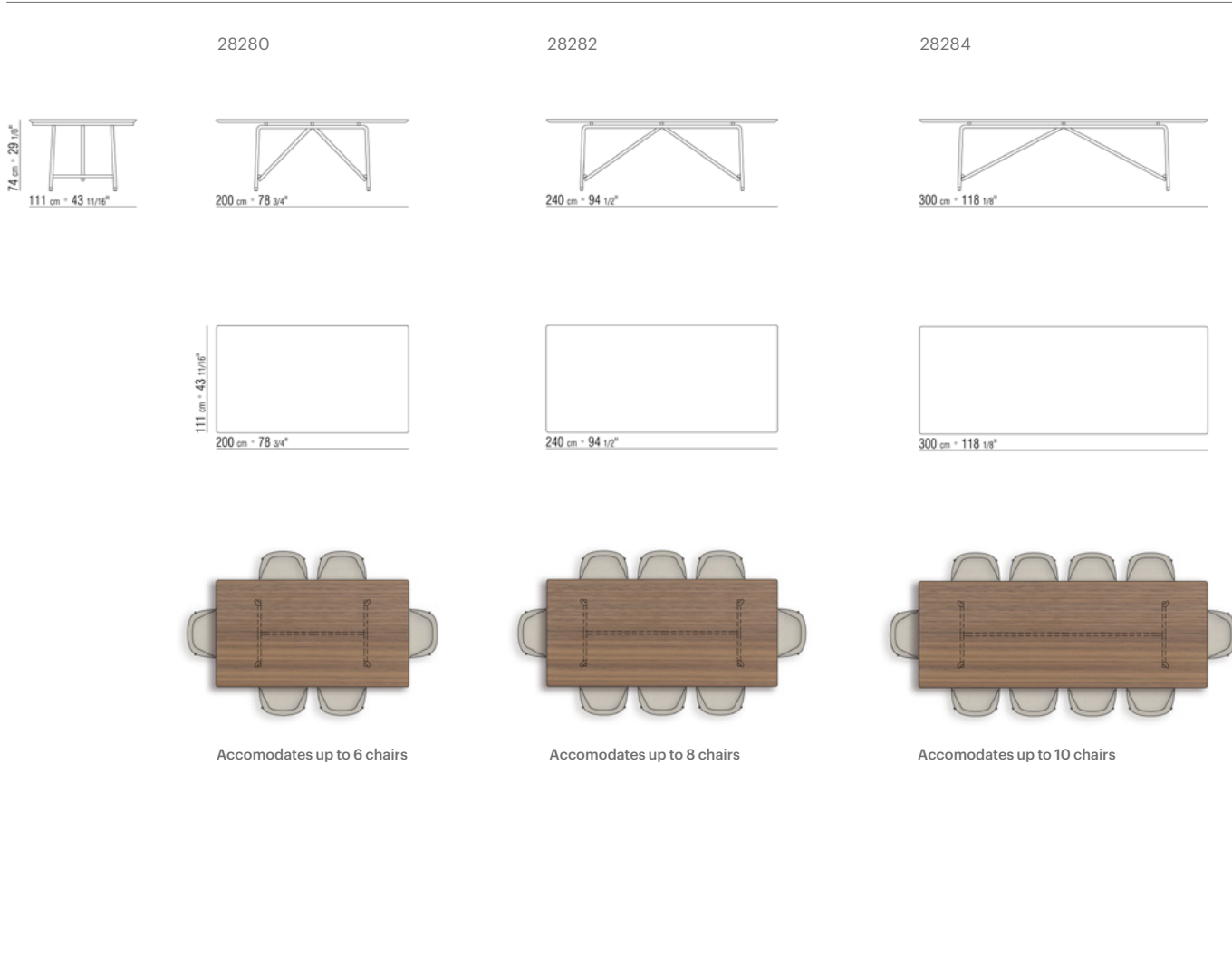





# Outdoor Collection 2021

La nuova collezione outdoor di Flexform è percorsa da freschezza ed inventiva sul piano dello stile e da una grande ricerca sul piano progettuale. Essa scaturisce da un'idea di progettazione responsabile, ogni arredo accuratamente sviluppato in chiave sostenibile, per massimizzarne la durabilità, prevedendo parti modulari e scomponibili, affinché la maggior parte di esse possa essere riciclata quando il prodotto avrà ultimato il suo ciclo vitale. Così legno, acciaio, alluminio, filati in polipropilene, tessuti e tutti i materiali che vengono impiegati da Flexform vengono accuratamente selezionati non solo perché perfettamente idonei a dar vita ad arredi che incarnano la perfetta sintesi tra un ideale di rilassata eleganza ed un elevato livello di confort, ma anche perché quando i prodotti avranno esaurito la loro funzione, la maggior parte delle componenti possa essere recuperata e dunque nuovamente utilizzata.

*The new Flexform outdoor collection is permeated with fresh, inventive style and pioneering design research.*

*Derived from a rational design concept, each piece of furniture is painstakingly developed to maximize sustainability and durability, making use of modular components, so that most parts can be recycled when the product has reached the end of its life cycle.*

*Thus, wood, steel, aluminum, polypropylene fibers, fabrics and all the materials used by Flexform are carefully selected not only because they are perfectly suited to produce furnishings that embody the ideal blend of casual elegance and superior comfort, but also because, when the products have run their course of usefulness, most of the components can be recovered and re-used.*

# Index

FREEPORT



238

HAMPTONS



208

LEE OUTDOOR



258

FREEPORT



238

HAMPTONS



208

ECHOES OUTDOOR



308

ECHOES OUTDOOR



308

LEE OUTDOOR



258

ECHOES OUTDOOR



308

ECHOES OUTDOOR



308

ECHOES OUTDOOR



308



ANY DAY OUTDOOR



290

FLY OUTDOOR



270

ZEFIRO OUTDOOR



278

BERRY OUTDOOR



298

# Hamptons

Antonio Citterio

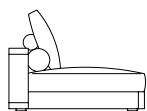

SOFAS  
SECTIONAL SOFAS  
OTTOMANS  
CHAISE LONGUES  
DAYBEDS

Il progetto del divano Hamptons valorizza appieno tutte le qualità del massello di iroko, un'essenza calda e duttile, le cui eccezionali prestazioni in ambito outdoor, ne fanno il materiale d'elezione per la realizzazione di arredi dal fascino intramontabile.

Il divano Hamptons si mantiene sollevato da terra a mezzo di piedini in alluminio che consentono di preservare la struttura in legno dal contatto diretto con il pavimento e dall'umidità.

Le basi in legno previste nelle finiture naturale, tinto grigio e laccato bianco accolgono cuscini ampi e generosamente imbottiti, rifiniti da un profilo in gros grain che può essere realizzato ton-sur-ton oppure in contrasto, un elegante dettaglio di confezione che dimostra come Flexform mantenga la spiccata vocazione alla sartorialità anche nella realizzazione di prodotti outdoor. Per ottenere un elevato grado di confort e sorreggere in modo ottimale la schiena, i cuscini con rullo poggiano su altri cuscini a rullo, creando un originale effetto estetico.

Il sistema di sedute Hamptons comprende anche un lettino reclinabile che può essere utilizzato da solo oppure essere integrato in composizioni variamente articolate a mezzo di giunti che si possono agganciare e sganciare con grande facilità. Per rendere le configurazioni ancora più funzionali è possibile inserire elementi con superfici in pietra da utilizzarsi quali piani d'appoggio.

I lettini Hamptons possono essere facilmente impilati per poterli riporre in un luogo riparato al termine della stagione o in caso di necessità. Se non utilizzate per lunghi periodi, si consiglia di coprire le sedute Hamptons con le apposite fodere al fine di mantenerle in buone condizioni e preservarne lo stato originale il più a lungo possibile.

*The Hamptons sofa design fully maximizes the qualities of solid iroko, a warm, versatile type of wood whose exceptional outdoor performance makes it the material of choice for furnishings with timeless appeal.*

*The Hamptons sofa sits on aluminum feet that protect the wood structure from direct contact with the ground and humidity.*

*The wood bases, available in natural finish, stained grey or lacquered white finish, welcome roomy, generously padded cushions outlined with elegant grosgrain piping that can be crafted tone-on-tone or in a contrasting shade - an elegant detail that epitomizes the firm Flexform commitment to fine tailoring, even in its outdoor products.*

*To achieve superlative comfort and provide optimal support for the back, the back cushions rest on large bolsters, creating a unique aesthetic effect.*

*The Hamptons seating system also includes a reclinable daybed that can stand alone or be integrated into various arrangements by means of fasteners that can easily be hooked and unhooked.*

*For even more functional arrangements, stone-topped pieces can be included for use as table-top surfaces.*

*The Hamptons daybeds are easily stackable for safe storage at the end of the season or in case of necessity.*

*If left unused for lengthy periods of time, we recommend that the Hamptons seating be protected with their respective covers to keep them in top condition and maintain their original appearance as long as possible.*

*Most of the parts used in the Hamptons seating can be recycled.*







**Hamptons**  
Antonio Citterio





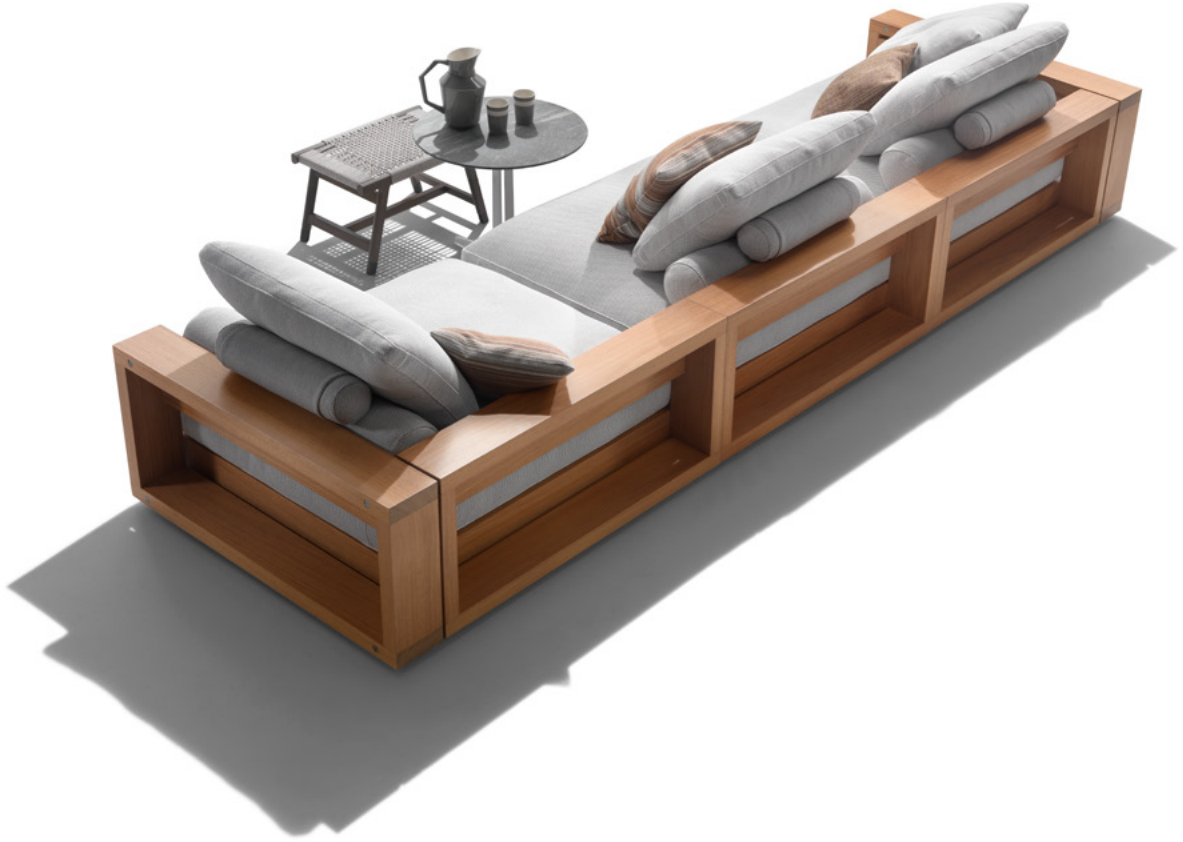







**Hamptons**  
Antonio Citterio





**Hamptons**  
Antonio Citterio











**Hamptons**  
Antonio Citterio

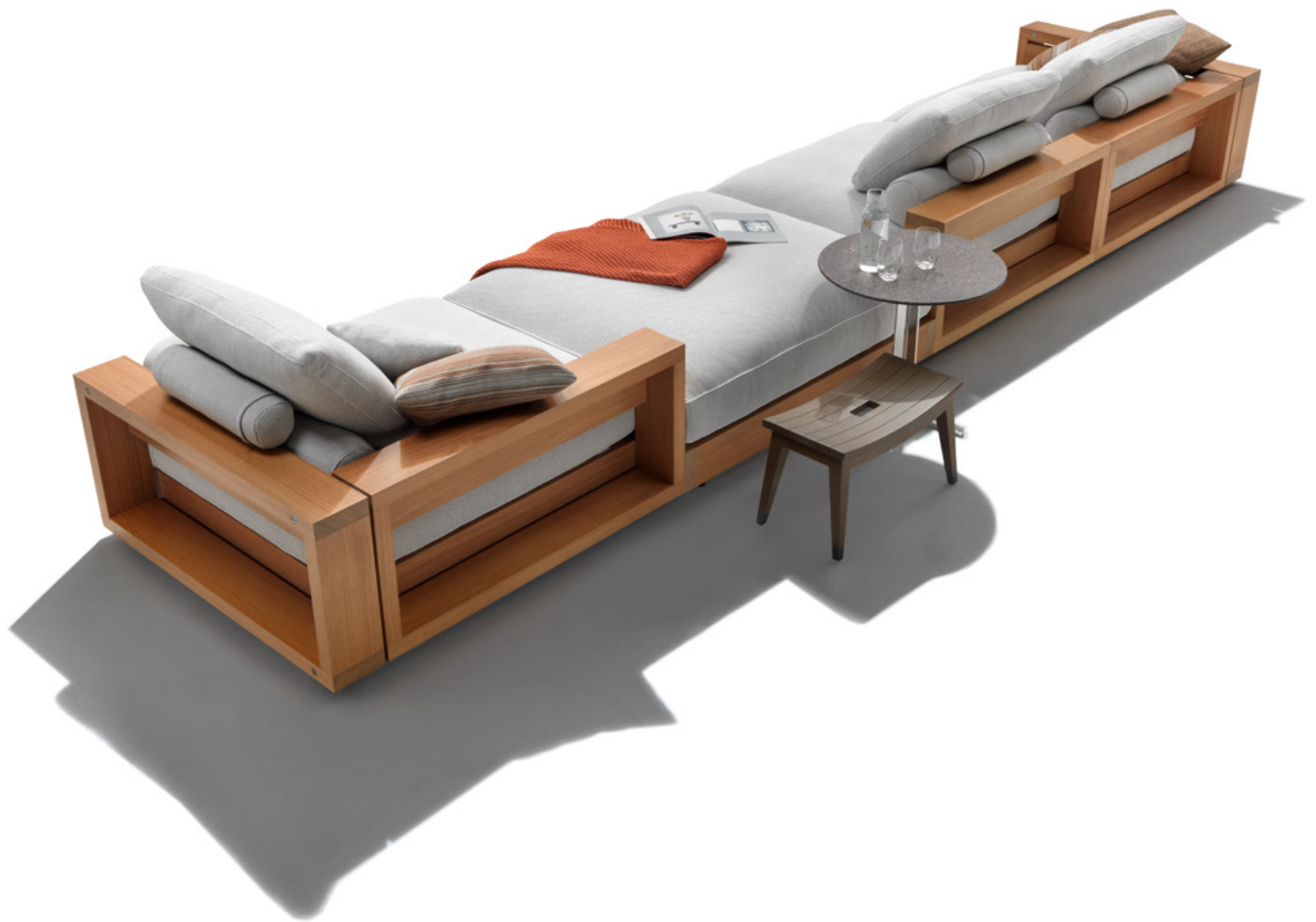

**Hamptons**  
Antonio Citterio









**Hamptons**  
Antonio Citterio





**Hamptons**  
Antonio Citterio







**Hamptons**  
Antonio Citterio









**Hamptons**  
Antonio Citterio





**Hamptons**  
Antonio Citterio







**Hamptons**  
Antonio Citterio









**Hamptons**  
Antonio Citterio





# Hamptons Data Sheet

Antonio Citterio

## Divano - Divano componibile Pouf - Tavolino

### Struttura

in legno massello di iroko nelle finiture naturale, tinto grigio, laccato bianco con cinghie elastiche idrorepellenti nei colori bianco 9007, sabbia 9001, grigio 9003, antracite 9005. Tiranti e viti in acciaio inox 316, distanziali in zama pressofusa verniciati a forno con polveri epossidiche con finitura trasparente

### Bracciolo

in legno massello di iroko nelle finiture naturale, tinto grigio, laccato bianco. Tiranti e viti in acciaio inox 316, distanziali in zama pressofusa verniciati a forno con polveri epossidiche con finitura trasparente

### Cuscino seduta

in poliuretano espanso e fibra di poliestere rivestito in tessuto protettivo accoppiato idrorepellente

### Cuscino schienale con rullo

in fibra di poliestere e fodera idrorepellente

### Cuscino a rullo

in fibra di poliestere e fodera idrorepellente

### Cuscini optional

in fibra di poliestere e fodera idrorepellente, a richiesta con supplemento di prezzo

### Profilo rivestimento

la confezione prevede un profilo in gros grain che può essere realizzato in tutti i colori della cartella campioni

### Rivestimento

in tessuto sfoderabile

### Tavolino

### Struttura

in legno massello di iroko nelle finiture naturale, tinto grigio, laccato bianco con piano di appoggio in pietra nelle tipologie porfido, Cardoso, lava, Beola argentata. È previsto un sottopiano di legno multistrato verniciato

### Piedi

in alluminio. Appoggio a terra su puntali in materiale termoplastico

### Cover

in materiale impermeabile. A richiesta e con supplemento di prezzo

## Sofa - Sectional sofa - Ottoman - Coffee table

### Structure

in solid iroko with natural, stained grey or lacquered white finish with water-repellent elastic webbing in the following colors: white 9007, sand 9001, grey 9003, anthracite 9005. Supports and screws in 316 stainless steel, spacers in die-cast zama with transparent epoxy powder-coat finish

### Armrest

in solid iroko with natural, stained grey or lacquered white finish. Supports and screws in 316 stainless steel, spacers in die-cast zama with transparent epoxy powder-coat finish

### Seat cushion

in polyurethane foam and polyester fiber, covered with a protective, water-repellent laminated fabric

### Backrest cushion with bolster

in polyester fiber and water-repellent casing

### Bolster

in polyester fiber with water-repellent casing

### Optional cushions

in polyester fiber and water-repellent casing; upon request, with upcharge

### Upholstery piping

fine tailoring includes grosgrain piping that can be crafted in all the colors on the sample board

### Upholstery

in removable fabric

### Coffee table

### Structure

in solid iroko with natural, stained grey, or lacquered white finish with table top in the following types of stone: porphyry, Cardoso, lava or Beola Argentata (silvery-green gneiss). Comes with an under panel in painted plywood

### Feet

in aluminum. Rests on tips made of thermoplastic material

### Cover

in waterproof material; upon request, with upcharge



289A3

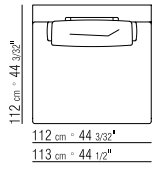
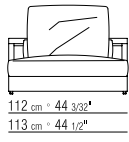
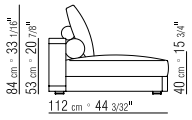

289G1

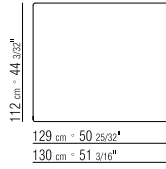
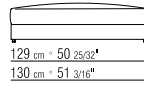
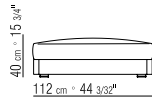

289F1

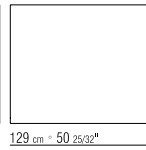
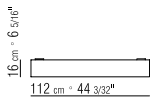
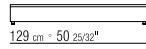
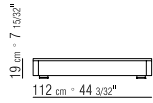
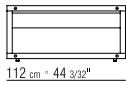
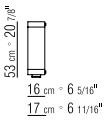

289M5

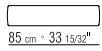

289M6



289M7



289M8

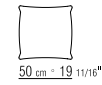

289M9



# Hamptons Data Sheet

Antonio Citterio

## Letting

### Struttura

in legno massello di iroko nelle finiture naturale, tinto grigio, laccato bianco. Tiranti e viti in acciaio inox 316 e rivestita con cinghie elastiche idrorepellenti nei colori bianco 9007, sabbia 9001, grigio 9003, antracite 9005

### Schienale reclinabile

in legno massello di iroko nelle finiture naturale, tinto grigio, laccato bianco. Sistema di inclinazione dello schienale in acciaio inox 316 elettrolucidato e cremagliera in materiale termoplastico di colore grigio

### Cuscino a rullo

in fibra di poliestere e fodera idrorepellente, a richiesta con supplemento di prezzo

### Cuscino seduta e schienale

in fibra di poliestere con inserto in materiale indeformabile a densità unica rivestito in tessuto idrorepellente

### Profilo rivestimento

la confezione prevede un profilo in gros grain che può essere realizzato in tutti i colori della cartella campioni

### Rivestimento

in tessuto sfoderabile

### Piedi

in alluminio nelle finiture spazzolato opaco, brunito. Appoggio a terra su puntali in materiale termoplastico

### Cover

in materiale impermeabile. A richiesta e con supplemento di prezzo

## Daybed

### Structure

in solid iroko with natural, stained grey or lacquered white finish. Supports and screws in 316 stainless steel, covered with water-repellent elastic webbing in the following colors: white 9007, sand 9001, grey 9003, anthracite 9005

### Reclinable backrest

in solid iroko with natural, stained grey or lacquered white finish. Backrest recliner system in electropolished 316 stainless steel and bracket in grey thermoplastic material

### Bolster

in polyester fiber with water-repellent casing; upon request with upcharge

### Seat and backrest cushion

in polyester fiber with insert in crushproof single-density material, covered in water repellent fabric

### Upholstery piping

fine tailoring includes grosgrain piping that can be crafted in all the colors on the sample board

### Upholstery

in removable fabric

### Feet

in aluminum with matte brushed or burnished finish. Rests on tips made of thermoplastic material

### Cover

in waterproof material; upon request, with upcharge

289G8

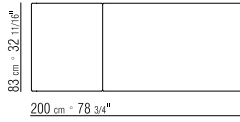
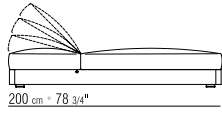
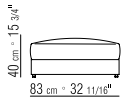

289M4

289M7

289M8





# Freeport

Antonio Citterio

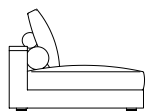

SOFAS  
SECTIONAL SOFAS  
OTTOMANS  
CHAISE LONGUES  
DAYBEDS

Un sistema di sedute caratterizzato da linee pulite e squadrate, la cui base è interamente realizzata in alluminio, un materiale leggero ma estremamente robusto e dunque particolarmente adatto per l'utilizzo in ambienti outdoor per la sua notevole resistenza alla corrosione indotta dagli agenti atmosferici e dalla salsedine.

Alla rigorosa pulizia formale della struttura in alluminio verniciato a polvere epossidica in una raffinata gamma cromatica, sono abbinati ampi cuscini di seduta e schienale dalle forme anch'esse squadrate ma generosamente imbottite e rifinite da un elegante profilo in gros grain.

Il sistema di sedute Freeport comprende anche un lettino reclinabile che può essere utilizzato da solo oppure essere integrato in composizioni variamente articolate a mezzo di giunti che si possono agganciare e sganciare con grande facilità. Per rendere le configurazioni ancora più funzionali è possibile inserire elementi con superfici in pietra da utilizzarsi quali piani d'appoggio.

I lettini Freeport possono essere facilmente impilati per poterli riporre in un luogo riparato al termine della stagione o in caso di necessità.

Se non utilizzate per lunghi periodi, si consiglia di coprire le sedute Freeport con le apposite fodere al fine di mantenerle in buone condizioni e preservarne lo stato originale il più a lungo possibile.

La maggior parte dei componenti utilizzati per la realizzazione degli elementi Freeport possono essere riciclati.

*This seating system features clean, square lines. The base is made entirely of aluminum, a lightweight but extremely robust material that is especially suited to use in outdoor settings, given its remarkable resistance to corrosion caused by weather and salt water. The meticulously clean lines of the aluminum structure, epoxy powder-coated in a sophisticated color palette, are combined with roomy seat and backrest cushions that are also square but generously padded and outlined with elegant grosgrain piping. The Freeport seating system also includes a reclining daybed that can stand alone or be integrated into various arrangements by means of fasteners that are easily hooked and unhooked. For even more functional arrangements, stone-topped pieces can be included for use as table-top surfaces.*

*The Freeport daybeds are easily stackable for safe storage at the end of the season or in case of necessity.*

*If left unused for lengthy periods of time, we recommend that the Freeport seating be protected with their respective covers to keep them in top condition and maintain their original appearance as long as possible.*

*Most of the parts used in the Freeport seating can be recycled.*







**Freeport**  
Antonio Citterio











**Freeport**  
Antonio Citterio





**Freeport**  
Antonio Citterio





**Freeport**  
Antonio Citterio









**Freeport**  
Antonio Citterio







**Freeport**  
Antonio Citterio













# Freeport Data Sheet

Antonio Citterio

## Divano - Divano componibile Pouf - Tavolino

### Struttura

in alluminio verniciato a forno con polveri epossidiche nei colori bianco 100, rosso vino 405, verde kaki 705, brunito, grigio o nella finitura opaca nei colori sabbia, verde, mattone e bianco. Piano in legno massello di iroko nelle finiture naturale, tinto grigio, laccato bianco. Cinghie elastiche idrorepellenti nei colori bianco 9007, sabbia 9001, grigio 9003, antracite 9005. Tiranti e viti in acciaio inox 316, distanziali in zama pressofusa verniciati a forno con polveri epossidiche con finitura trasparente

### Bracciolo

in alluminio verniciato a forno con polveri epossidiche nei colori bianco 100, rosso vino 405, verde kaki 705, brunito, grigio o nella finitura opaca nei colori sabbia, verde, mattone e bianco. Piano in legno massello di iroko nelle finiture naturale, tinto grigio, laccato bianco. Tiranti e viti in acciaio inox 316, distanziali in zama pressofusa verniciati a forno con polveri epossidiche con finitura trasparente

### Cuscino seduta

in poliuretano espanso e fibra di poliestere rivestito in tessuto protettivo accoppiato idrorepellente

### Cuscino schienale

con rullo in fibra di poliestere e fodera idrorepellente

### Cuscino a rullo

in fibra di poliestere e fodera idrorepellente

### Cuscini optional

in fibra di poliestere e fodera idrorepellente, a richiesta con supplemento di prezzo

### Profilo rivestimento

la confezione prevede un profilo in gros grain che può essere realizzato in tutti i colori della cartella campioni

### Rivestimento

in tessuto sfoderabile

## Tavolino

### Struttura

in alluminio verniciato a forno con polveri epossidiche nei colori bianco 100, rosso vino 405, verde kaki 705, brunito, grigio o nella finitura opaca nei colori sabbia, verde, mattone e bianco. Piano di appoggio in pietra nelle tipologie porfido, Cardoso, lavica, Beola argentata. È previsto un sottopiano di legno multistrato verniciato.

### Piedi

in alluminio. Appoggio a terra su puntali in materiale termoplastico

### Cover

in materiale impermeabile. A richiesta e con supplemento di prezzo

## Sofa - Sectional sofa - Ottoman - Coffee table

### Structure

in aluminum with epoxy powder-coat finish in the following colors: white 100, wine red 405, khaki green 705, burnished or grey; or with matte finish in sand, green, brick or white. Top in solid iroko with natural, stained grey or lacquered white finish. Water-repellent elastic webbing in the following colors: white 9007, sand 9001, grey 9003, anthracite 9005. Supports and screws in 316 stainless steel, spacers in die-cast zama with transparent epoxy powder-coat finish

### Armrest

in aluminum with epoxy powder-coat finish in the following colors: white 100, wine red 405, khaki green 705, burnished or grey; or with matte finish in sand, green, brick or white. Top in solid iroko with natural, stained grey or lacquered white finish. Supports and screws in 316 stainless steel, spacers in die-cast zama with transparent epoxy powder-coat finish

### Seat cushion

in polyurethane foam and polyester fiber, covered with a protective, water-repellent laminated fabric

### Backrest cushion

with bolster in polyester fiber and water-repellent casing

### Bolster

in polyester fiber with water-repellent casing

### Optional cushions

in polyester fiber and water-repellent casing; upon request, with upcharge

### Upholstery piping

fine tailoring includes grosgrain piping that can be crafted in all the colors on the sample board

### Upholstery

in removable fabric

## Coffee table

### Structure

in aluminum with epoxy powder-coat finish in the following colors: white 100, wine red 405, khaki green 705, burnished or grey; or with matte finish in sand, green, brick or white. Top in the following types of stone: porphyry, Cardoso, lava stone, Beola Argentata. Comes with an under panel in painted plywood

### Feet

in aluminum. Rests on tips made of thermoplastic material

### Cover

in waterproof material; upon request, with upcharge

285A3

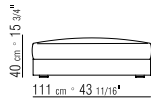
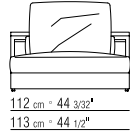
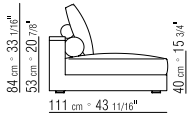

285G1

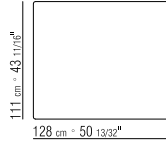
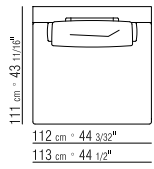
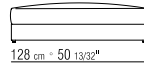

285F1

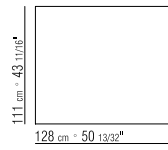
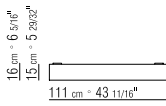
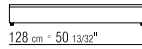
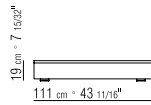
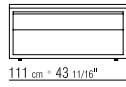
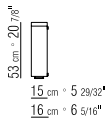

285M5

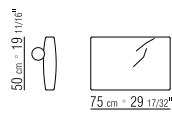
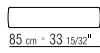

285M6

285M7

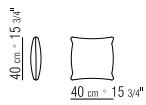

285M8

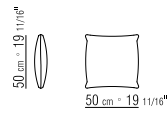

285M9

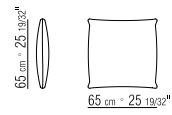



# Freeport Data Sheet

Antonio Citterio

## Letino

### Struttura

in alluminio verniciato a forno con polveri epossidiche nei colori bianco 100, rosso vino 405, verde kaki 705, brunito, grigio, o nella finitura opaca nei colori sabbia, verde, mattone e bianco. Cinghie elastiche idrorepellenti nei colori bianco 9007, sabbia 9001, grigio 9003, antracite 9005.

### Schienale reclinabile

in legno massello di iroko nelle finiture naturale, tinto grigio, laccato bianco. Sistema di inclinazione dello schienale in acciaio inox 316 elettrolucidato e cremagliera in materiale termoplastico di colore grigio

### Cuscino a rullo

in fibra di poliestere e fodera idrorepellente, a richiesta con supplemento di prezzo

### Cuscino seduta e schienale

in fibra di poliestere con inserto in materiale indeformabile a densità unica rivestito in tessuto idrorepellente

### Profilo rivestimento

la confezione prevede un profilo in gros grain che può essere realizzato in tutti i colori della cartella campioni

### Piedi

in alluminio. Appoggio a terra su puntali in materiale termoplastico

### Rivestimento

in tessuto sfoderabile

### Cover

in materiale impermeabile.  
A richiesta e con supplemento di prezzo

## Daybed

### Structure

in aluminum with epoxy powder-coat finish in the following colors: white 100, wine red 405, khaki green 705, burnished or grey; or with matte finish in sand, green, brick or white. Water-repellent elastic webbing in the following colors: white 9007, sand 9001, grey 9003, anthracite 9005

### Reclinable backrest

in solid iroko with natural, stained grey or lacquered white finish.  
Backrest Recliner System in electropolished 316 stainless steel and bracket in grey thermoplastic material

### Bolster

in polyester fiber with water-repellent casing; upon request with upcharge

### Seat and backrest cushion

in polyester fiber with insert in crushproof single-density material, covered in water-repellent fabric

### Upholstery piping

fine tailoring includes grosgrain piping that can be crafted in all the colors on the sample board

### Feet

in aluminum. Rests on tips made of thermoplastic material

### Upholstery

in removable fabric

### Cover

in waterproof material;  
upon request, with upcharge

285G8

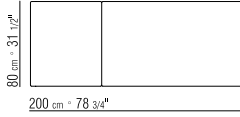
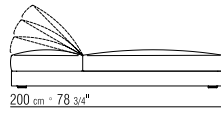
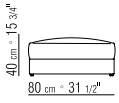

285M4

285M7



# Lee Outdoor

Antonio Citterio



ARMCHAIRS  
OTTOMANS

La struttura della poltrona e del divanetto Lee Outdoor è interamente realizzata in massello di iroko, gli incastri eseguiti secondo la tradizione, con l'orgoglio di lavorare un materiale nobile come il legno e dare vita a qualcosa destinato a rimanere nel tempo.

L' intreccio che caratterizza la seduta e lo schienale è in cordoncino di polipropilene intrecciato a mano, proposto in una raffinata palette cromatica.

Per rendere la poltrona ed il divanetto Lee Outdoor ancora più confortevoli è possibile aggiungere dei pratici cuscini optional.

Se non utilizzate per lunghi periodi, si consiglia di coprire le sedute Lee Outdoor con le apposite fodere al fine di mantenerle in buone condizioni e preservarne lo stato originale il più a lungo possibile.

La maggior parte dei componenti utilizzati per la realizzazione degli elementi Lee Outdoor possono essere riciclati.

*The structure of the Lee Outdoor armchair and settee is made entirely of solid iroko. Using traditional methods, the joinery is artisan-crafted with the satisfaction of working a quintessential material like wood and creating a product sure to last a lifetime.*

*The seat and backrest are in hand-woven polypropylene cord, available in a sophisticated palette of colors.*

*Practical optional cushions are available to lend added comfort to the Lee Outdoor armchair and settee.*

*If left unused for lengthy periods of time, we recommend that the Lee Outdoor seating be protected with their respective covers to keep them in top condition and maintain their original appearance as long as possible.*

*Most of the parts used in the Lee Outdoor seating can be recycled.*









**Lee Outdoor**  
Antonio Citterio





**Lee Outdoor**  
Antonio Citterio





**Lee Outdoor**  
Antonio Citterio







**Lee Outdoor**  
Antonio Citterio







# Lee Outdoor Data Sheet

Antonio Citterio

## Struttura

in legno massello di iroko nelle finiture naturale, tinto grigio, laccato bianco. Intreccio in pvc estruso con anima di nylon nei colori antracite 7005, bordeaux 7002, bianco 7007, panna 7001, marrone 7004, verde 7006 o in cordoncino in polipropilene nei colori sabbia 8001, antracite 8005, bordeaux 8002, verde 8006, bianco 8007, marrone 8004 o in cordoncino in polipropilene opaco nei colori naturale 8102, ghiaccio 8103, antracite 8105, paglia 8101

## Cuscino seduta/schienale

in fibra di poliestere e fodera idrorepellente, su richiesta con supplemento di prezzo

## Piedi

in zama pressofusa nelle finiture spazzolato opaco, brunito. Appoggio a terra su puntali in materiale termoplastico

## Rivestimento cuscini seduta/schienale

in tessuto sfoderabile

## Cover

in materiale impermeabile.  
A richiesta e con supplemento di prezzo

## Structure

*in solid iroko wood with natural, stained grey or lacquered white finish. Woven extruded pvc with nylon core in anthracite 7005, bordeaux 7002, white 7007, cream 7001, brown 7004, green 7006; or, in polypropylene cord in sand 8001, anthracite 8005, bordeaux 8002, green 8006, white 8007, brown 8004; or, in matt polypropylene cord in natural 8102, ice 8103, anthracite 8105 or straw 8101 color*

## Seat/backrest cushion

*in polyester fiber with water-repellent upholstery; upon request, with upcharge*

## Feet

*in die-cast zama with matt brushed or burnished finish. Rests on tips made of thermoplastic material*

## Seat/backrest cushion upholstery

*in removable fabric*

## Cover

*in waterproof material; cover is upon request, with upcharge*

284A3

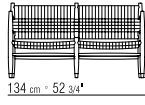
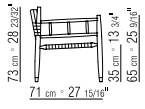

284C1

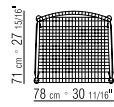
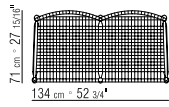
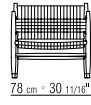
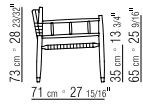

284M8

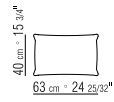
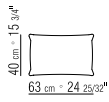

284M9

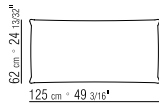
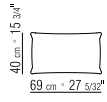

# Fly Outdoor

Antonio Citterio

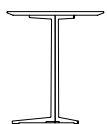

DINING TABLES

La famiglia di tavoli e tavolini Fly Outdoor vede l'inserimento di un tavolo dalle misure particolari, pensato per una precisa funzione di utilizzo.

Espressamente progettato in abbinamento agli sgabelli della collezione outdoor di Flexform, il nuovo tavolo Fly Outdoor è alto cm 93 mentre il piano è previsto nella misura diametro cm 80.

La struttura del tavolo è in acciaio inossidabile, disponibile anche nella finitura con verniciatura a polvere epossidica in un'ampia gamma cromatica.

Il piano è proposto in una varietà di eleganti pietre per esterno: Beola argentata, pietra lavica, pietra del Cardoso e porfido oppure nella versione con doghe in massello di iroko.

La maggior parte dei componenti utilizzati per la realizzazione del tavolo Fly Outdoor possono essere riciclati.

*The Fly Outdoor family of tables, coffee and side tables expands to include a specially-sized table, designed for a specific function and use.*

*Custom-designed to be paired with the bar stools in the Flexform collection, the new Fly Outdoor table is 93 cm high and the top measures 80 cm in diameter.*

*The structure of the table is in stainless steel; it is also available with epoxy powder-coat finish in a wide range of colors.*

*The top comes in an array of elegant types of stone suitable for outdoor use: Beola argentata, lava stone, pietra del Cardoso and porphyry, or with solid iroko wood slats.*

*Most of the parts used in the Fly Outdoor table can be recycled.*









**Fly Outdoor**  
Antonio Citterio





**Fly Outdoor**  
Antonio Citterio









# Fly Outdoor Data Sheet

Antonio Citterio

## Struttura

in acciaio inox 316 nelle finiture elettrolucidato o verniciato a forno con polveri epossidiche nei colori bianco 100, rosso vino 405, verde kaki 705, brunito o nella finitura opaca nei colori sabbia, verde, mattone e bianco

## Piano

in pietra nelle tipologie lavica, porfido, Cardoso, Beola argentata;  
in legno massello di iroko nelle finiture naturale, tinto grigio, laccato bianco

## Piedi

appoggio a terra su puntali in materiale termoplastico

## Cover

in materiale impermeabile.  
A richiesta e con supplemento di prezzo

## Structure

in stainless steel 316 with electropolished or epoxy-powder-coated finish in white 100, wine red 405, khaki green 705, or burnished; or with matte finish in sand, green, brick or white

## Top

in the following types of stone: lava stone, porphyry, Cardoso, Beola Argentata; in solid iroko wood with natural finish, stained grey, or lacquered white finish

## Feet

rests on tips made of thermoplastic material

## Cover

in waterproof material;  
cover is upon request, with upcharge



---

14XL8

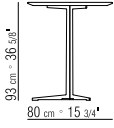

14XM8

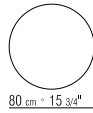
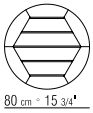
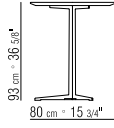

# Zefiro Outdoor

Antonio Citterio

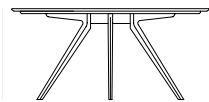

DINING TABLES

Levigato al tatto, privo di spigoli e asperità, dotato di eccezionali proprietà di resistenza all'usura e all'azione degli agenti atmosferici: è il piano in doghe di iroko massello proposto come novità per la famiglia di tavoli da pranzo Zefiro Outdoor. Le slanciate gambe in alluminio pressofuso sono disponibili nella finitura con verniciatura a polvere in una gamma di eleganti cromie, oltre che nelle versioni brunito e satinato. I piani, oltre che in pietra, sono realizzati con doghe in massello di iroko che, nella versione tonda, sono disposte in modo da creare un elegante disegno. La maggior parte dei componenti utilizzati per la realizzazione del tavolo Zefiro Outdoor possono essere riciclati.

*Smooth to the touch, free of sharp corners and rough edges, exceptionally resistant to wear and to the weather, the table top is made of solid iroko slats, the latest innovation in the family of Zefiro Outdoor dining tables. The sleek cast-aluminum legs are epoxy powder-coated in a palette of elegant colors, or with burnished or satin finish. In addition to stone, the tops are made of solid iroko slats that, in the round version, are placed in an arrangement that creates an elegant design. Most of the parts used in the Zefiro Outdoor table can be recycled.*







**Zefiro Outdoor**  
Antonio Citterio









**Zefiro Outdoor**  
Antonio Citterio









**Zefiro Outdoor**  
Antonio Citterio





# Zefiro Outdoor Data Sheet

Antonio Citterio

## Struttura

in metallo e alluminio pressofuso nelle finiture spazzolato opaco o verniciato a forno con polveri epossidiche nei colori bianco 100, rosso vino 405, verde kaki 705, brunito o nella finitura opaca nei colori sabbia, verde, mattone e bianco. Appoggio a terra su puntali in materiale termoplastico. A richiesta puntale in alluminio per appoggio su superfici morbide

## Piano

in legno massello di iroko nelle finiture naturale, tinto grigio, laccato bianco

## Cover

in materiale impermeabile.  
A richiesta e con supplemento di prezzo

## Structure

*in metal and aluminum with epoxy powder-coat finish in the following colors: white 100, wine red 405, khaki green 705, burnished; or with matte finish in sand, green, brick or white.  
Rests on tips made of thermoplastic material.  
Upon request, aluminum tips for use on soft surfaces*

## Top

*in solid iroko with natural, stained grey or lacquered white finish*

## Cover

*in waterproof material; cover is upon request, with upcharge*

238L1

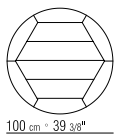
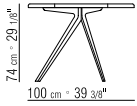

Accommodates up to 3 chairs

238L2

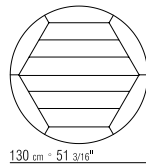
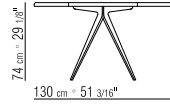

Accommodates up to 4 chairs

238L3

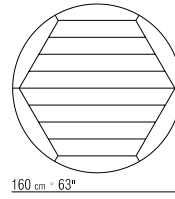
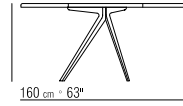

Accommodates up to 6 chairs

238L4

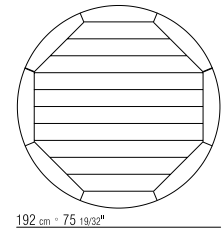
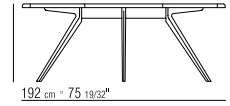

Accommodates up to 8 chairs

238M1

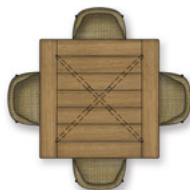
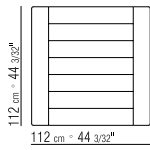
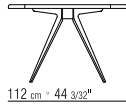
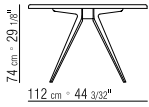

Accommodates up to 4 chairs

238M3

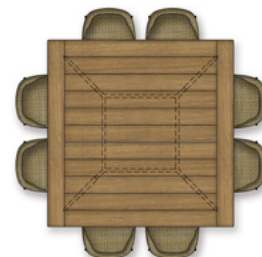
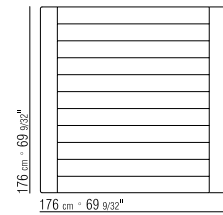
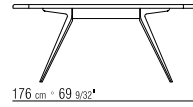
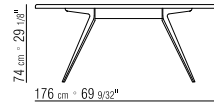

Accommodates up to 8 chairs





**Zefiro Outdoor**  
Antonio Citterio

238M5

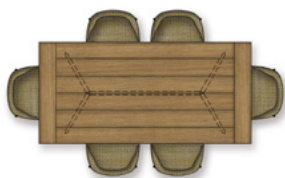
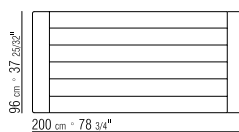
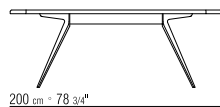
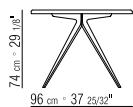

Accommodates up to 6 chairs

238M6

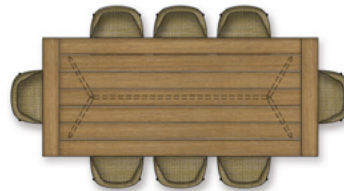
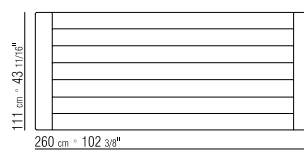
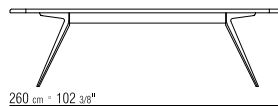
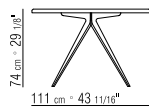

Accommodates up to 8 chairs

238M9

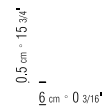

238M7

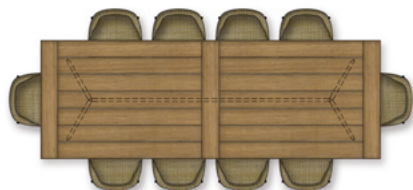
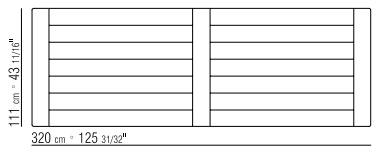
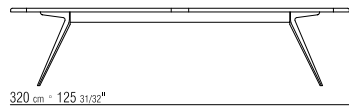
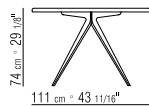

Accommodates up to 10 chairs

238M8

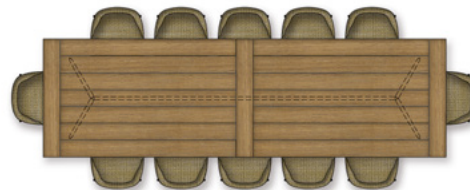
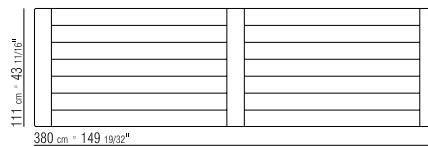
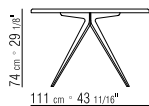

Accommodates up to 12 chairs

# Any Day Outdoor

Christophe Pillet

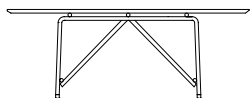

DINING TABLES

Il tavolo da pranzo Any Day Outdoor presenta linee pure ed un disegno essenziale, declinati nell'uso di materiali scelti per le loro caratteristiche estetiche e per le loro durabilità in ambienti esterni.

La rigorosa struttura in acciaio inox è disponibile anche nella finitura con verniciatura a polvere epossidica in un'ampia palette di colori raffinati.

Il piano realizzato con doghe in massello di iroko è invece proposto nelle finiture naturale, laccato bianco oppure tinto grigio oppure in una varietà di pietre naturali.

Il tavolo Any Day Outdoor è proposto in diverse dimensioni e può essere facilmente abbinato a tutte le sedie della collezione outdoor di Flexform.

La maggior parte dei componenti utilizzati per la realizzazione del tavolo Any Day Outdoor possono essere riciclati.

*The Any Day Outdoor dining table combines pure lines and a minimalist design expressed through materials selected for their beauty and durability in outdoor settings.*

*The sleek stainless-steel structure is also available with epoxy powder-coat finish in a wide array of sophisticated colors.*

*Instead, the top in solid iroko slats comes in natural finish, lacquered white finish or stained grey, or in a selection of types of natural stone.*

*The Any Day Outdoor table is available in several sizes and can easily be paired with any of the chairs in the Flexform Outdoor collection.*

*Most of the parts used in the Any Day Outdoor table can be recycled.*







**Any Day Outdoor**  
Christophe Pillet











**Any Day Outdoor**  
Christophe Pillet



# Any Day Outdoor Data Sheet

Christophe Pillet

## Struttura

in acciaio inox 316 nelle finiture elettrolucidato o verniciato a forno con polveri epossidiche nei colori bianco 100, rosso vino 405, verde kaki 705, brunito o nella finitura opaca nei colori sabbia, verde, mattone e bianco

## Piano

in legno massello di iroko nelle finiture naturale, tinto grigio, laccato bianco; in pietra nelle tipologie lavica, porfido, Cardoso, Beola argentata.  
L'articolo 282M4 non prevede il top in pietra

## Piedi

in alluminio. Appoggio a terra su puntali in materiale termoplastico

## Cover

in materiale impermeabile.  
A richiesta e con supplemento di prezzo

## Structure

*in electropolished 316 stainless steel; or, with epoxy powder-coat finish in white 100, wine red 405, or khaki green 705; burnished; or with matte finish in sand, green, brick or white*

## Top

*in solid iroko with natural, stained grey, or lacquered white finish; or in the following types of stone: lava, porphyry, Cardoso, or Beola Argentata. Article 282M4 is not available with stone top*

## Feet

*in aluminum. Rests on tips made of thermoplastic material*

## Cover

*in waterproof material; upon request, with upcharge*

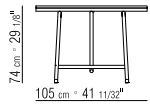

282L0

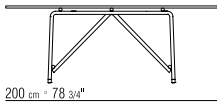

282L2

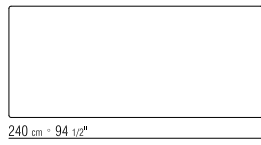
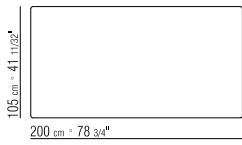
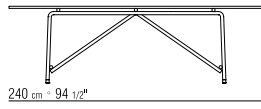

Accommodates up to 6 chairs

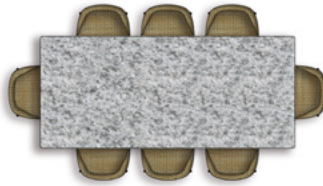

Accommodates up to 8 chairs

282M0

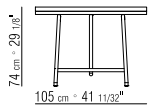

282M2

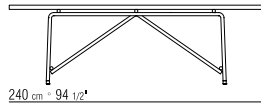

282M4

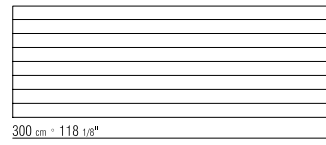
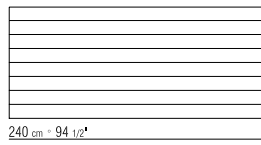
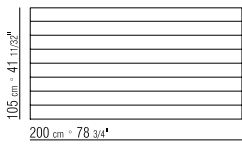
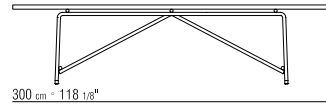

Accommodates up to 6 chairs

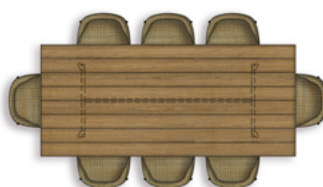

Accommodates up to 8 chairs

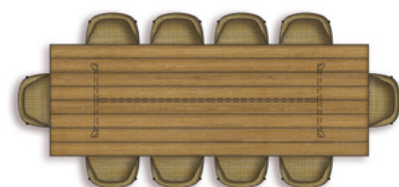

Accommodates up to 10 chairs



# Berry Outdoor

Design Center



COFFEE TABLES  
SIDE TABLES  
CONSOLES

Un'inedita combinazione materica per la versatile famiglia di tavolini Berry Outdoor.

Alla struttura in acciaio inox verniciata a polvere epossidica in numerosi e raffinati colori si associano piani in gres ceramico, un materiale composito dalle eccellenti performance in ambienti outdoor.

Un foro ricavato nella parte centrale del piano consente di evitare il ristagno dell'acqua piovana.

*An innovative combination of materials sets apart the versatile Berry Outdoor family of coffee and side tables.*

*The stainless-steel structure with epoxy powder-coat finish, available in an array of sophisticated colors, is paired with tops in ceramic stoneware, a composite material with excellent performance in outdoor settings.*

*A hole in the center of the top allows rainwater to drain off.*











**Berry Outdoor**  
Design Center



**Berry Outdoor**  
Design Center











# Berry Outdoor Data Sheet

## Design Center

### Struttura

in acciaio inox 304 nelle finiture elettrolucidato o verniciato a forno con polveri epossidiche nei colori bianco 100, rosso vino 405, verde kaki 705, brunito o nella finitura opaca nei colori sabbia, verde, mattone e bianco

### Piano

in ceramica nei colori avena, ostrica, grigio blu, verde muschio e mattone

### Piedi

poggia a terra su puntali in materiale termoplastico

### Cover

in materiale impermeabile.  
A richiesta e con supplemento di prezzo

### Structure

*in electropolished 304 stainless steel; or, with epoxy powder-coat finish in white 100, wine red 405, or khaki green 705; burnished; or with matte finish in sand, green, brick or white*

### Ceramic top

*in the following colors: oat, oyster, grey-blue, moss green or brick*

### Feet

*rest on tips made of thermoplastic material*

### Cover

*in water-repellent material. Cover is upon request, with upcharge*



---

291K0

291K1



# Echoes Outdoor

Christophe Pillet



ARMCHAIRS  
OTTOMANS  
CHAISE LONGUES  
DAYBEDS  
SMALL ARMCHAIRS  
DINING CHAIRS  
BAR STOOLS

La famiglia di sedute Echoes Outdoor connotata da linee leggere e da un'idea di misurata eleganza si arricchisce di nuovi elementi e comprende poltrone con e senza braccioli che possono essere corredate anche dal poggiatesta coordinato, sedie e poltroncine da pranzo, sgabelli e anche una snella chaise longue.

Il concept progettuale è costituito da un contrasto materico deciso: la struttura è in rigoroso acciaio inox mentre la seduta e lo schienale sono caratterizzati da un fine intreccio in cordoncino di polipropilene opaco nei colori naturale, ghiaccio, paglia ed antracite.

Se non utilizzate per lunghi periodi, si consiglia di coprire le sedute Echoes Outdoor con le apposite fodere al fine di mantenerle in buone condizioni e preservarne lo stato originale il più a lungo possibile.

La maggior parte dei componenti utilizzati per la realizzazione delle sedute Echoes Outdoor possono essere riciclati.

*Imbued with light, clean lines and a look of understated elegance, the Echoes Outdoor family of seating expands to include armchairs with and without armrests that coordinate nicely with matching ottomans, chairs and dining chairs, stools and also a slender chaise longue.*

*The design concept is based on a bold material contrast: the structure is in sleek stainless steel while the seat and backrest are made of fine woven matt polypropylene cord in natural, ice, straw or anthracite colors.*

*If left unused for lengthy periods of time, we recommend that the Echoes Outdoor seating be protected with their respective covers to keep them in top condition and maintain their original appearance as long as possible. Most of the parts used in the Echoes Outdoor seating can be recycled.*







**Echoes Outdoor**  
Christophe Pillet









**Echoes Outdoor**  
Christophe Pillet







**Echoes Outdoor**  
Christophe Pillet









**Echoes Outdoor**  
Christophe Pillet





# Echoes Outdoor

## Data Sheet

Christophe Pillet

### Struttura

in acciaio inox 316 nelle finiture elettrolucidato o verniciato a forno con polveri epossidiche nei colori bianco 100, rosso vino 405, verde kaki 705, brunito o nella finitura opaca nei colori sabbia, verde, mattone e bianco

### Seduta e schienale

in acciaio inox 316 con intreccio in cordoncino in polipropilene opaco nei colori naturale 8102, ghiaccio 8103, antracite 8105, paglia 8101

### Bracciolo poltrona

in acciaio inox 316 nelle finiture elettrolucidato o verniciato a forno con polveri epossidiche nei colori bianco 100, rosso vino 405, verde kaki 705, brunito o nella finitura opaca nei colori sabbia, verde, mattone e bianco e con inserto in legno massello di iroko nelle finiture naturale, tinto grigio, laccato bianco

### Cuscino seduta poltrona

in poliuretano espanso e fibra di poliestere e fodera idrorepellente. A richiesta con supplemento di prezzo

### Piedi

poggia a terra su puntali in materiale termoplastico

### Cover

in materiale impermeabile.  
A richiesta e con supplemento di prezzo

### Structure

*in electropolished 316 stainless steel; or, with epoxy powder-coat finish in white 100, wine red 405, or khaki green 705; burnished; or with matte finish in sand, green, brick or white*

### Seat and backrest

*in 316 stainless steel with woven matt polypropylene cord in natural 8102, ice 8103, anthracite 8105 or straw 8101 color*

### Armchair armrest

*in electropolished 316 stainless steel; or, with epoxy powder-coat finish in white 100, wine red 405, or khaki green 705; burnished; or with matte finish in sand, green, brick or white, and with insert in solid iroko with natural, stained grey, or lacquered white finish*

### Armchair seat cushion

*in polyurethane foam and polyester fiber, with water repellent upholstery. Upon request, with upcharge*

### Feet

*rest on tips made of thermoplastic material*

### Cover

*in waterproof material; cover is upon request, with upcharge*



280A1



280A5

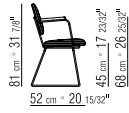

280C1



280C5

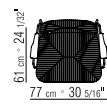
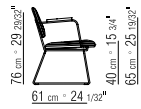

280M9

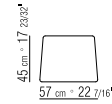

280D1

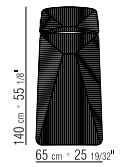

280GO



280HO

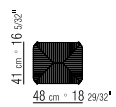

280H6



**FLEXFORM**

MADE IN ITALY

**Flexform** S.p.a.  
Via Einaudi 23/25  
20821 Meda (Mb) Italia  
tel +39 0362 3991  
info@flexform.it  
www.flexform.it

*Printed in Italy  
July 2021*

Flexform si riserva il diritto di apportare ai propri modelli qualsiasi miglioramento tecnologico ed estetico, comprese modifiche alle dimensioni e ai materiali, senza obbligo di preavviso.

*Flexform reserves the right to make to its models any technological and aesthetical improvement, including modifications of sizes and materials, without prior notice.*



Management  
System  
ISO 9001:2015



www.tuv.com  
ID 9108635793